



Data Communications and Networking

Fourth Edition

Forouzan

Chapter 13

Wired LANs: Ethernet

13-1 IEEE STANDARDS

In 1985, the Computer Society of the IEEE started a project, called Project 802, to set standards to enable intercommunication among equipment from a variety of manufacturers. Project 802 is a way of specifying functions of the physical layer and the data link layer of major LAN protocols.

Topics discussed in this section:

Data Link Layer

Physical Layer

Figure 13.1 *IEEE standard for LANs*

LLC: Logical link control
MAC: Media access control

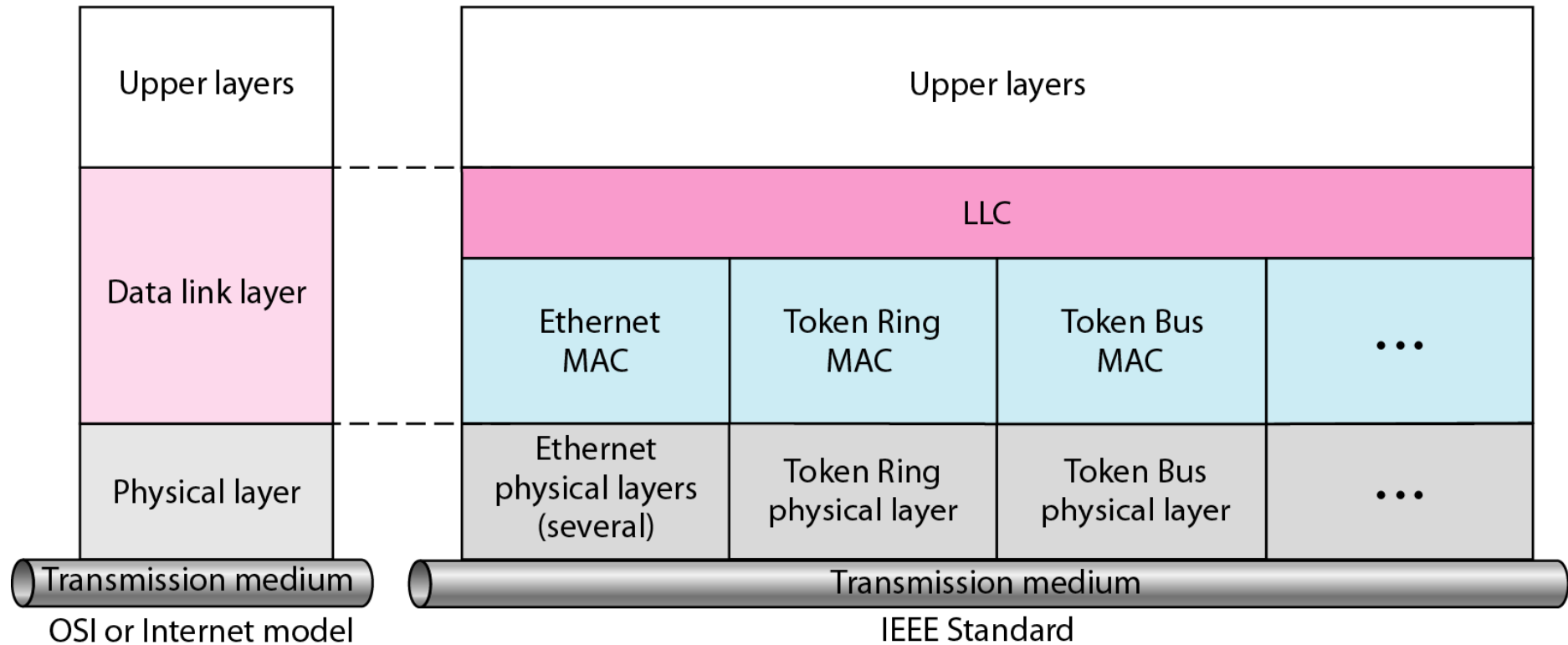
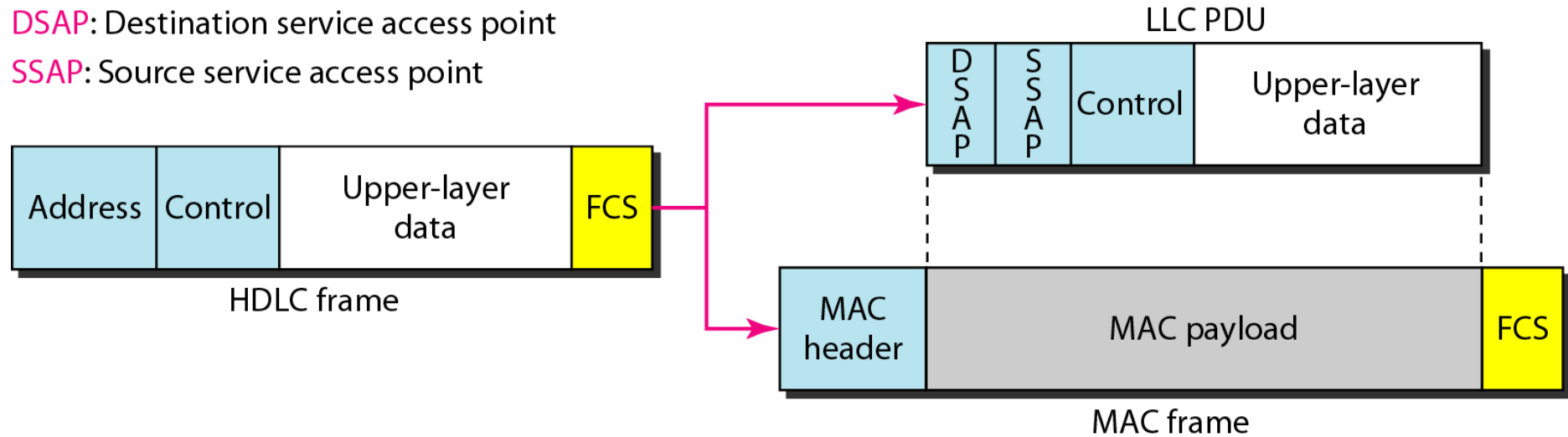

Figure 13.2 *HDLC frame compared with LLC and MAC frames*



13-2 STANDARD ETHERNET

*The original Ethernet was created in 1976 at Xerox's Palo Alto Research Center (PARC). Since then, it has gone through four generations. We briefly discuss the **Standard (or traditional) Ethernet** in this section.*

Topics discussed in this section:

MAC Sublayer

Physical Layer

Figure 13.3 *Ethernet evolution through four generations*

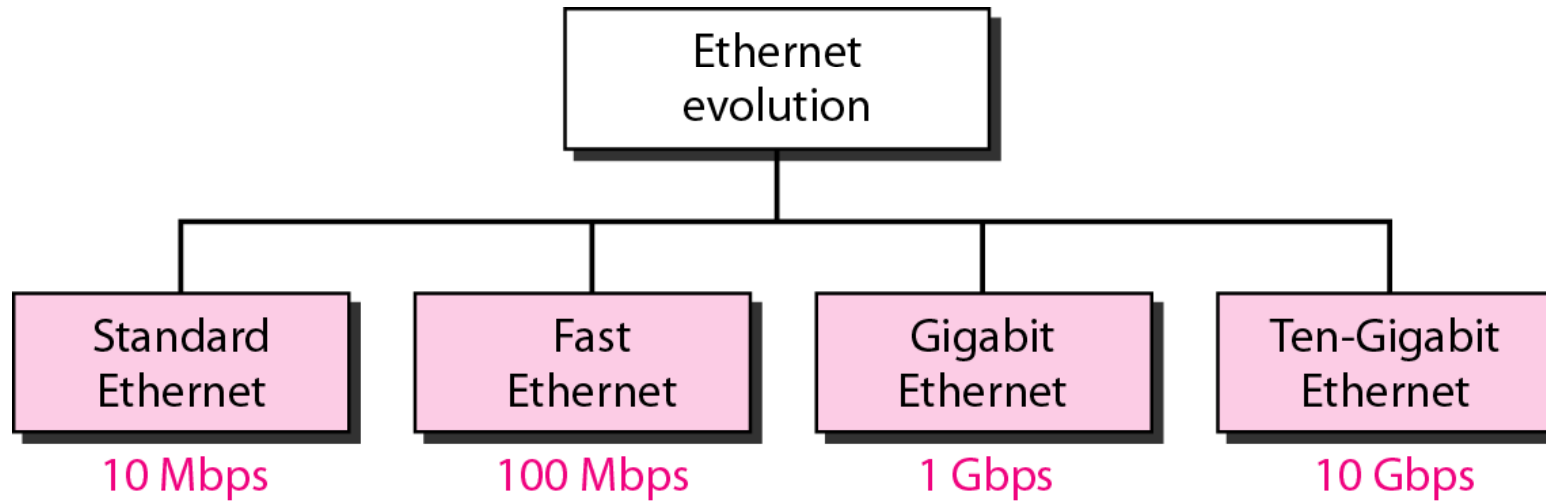

Figure 13.4 *802.3 MAC frame*

Preamble: 56 bits of alternating 1s and 0s.

SFD: Start frame delimiter, flag (10101011)

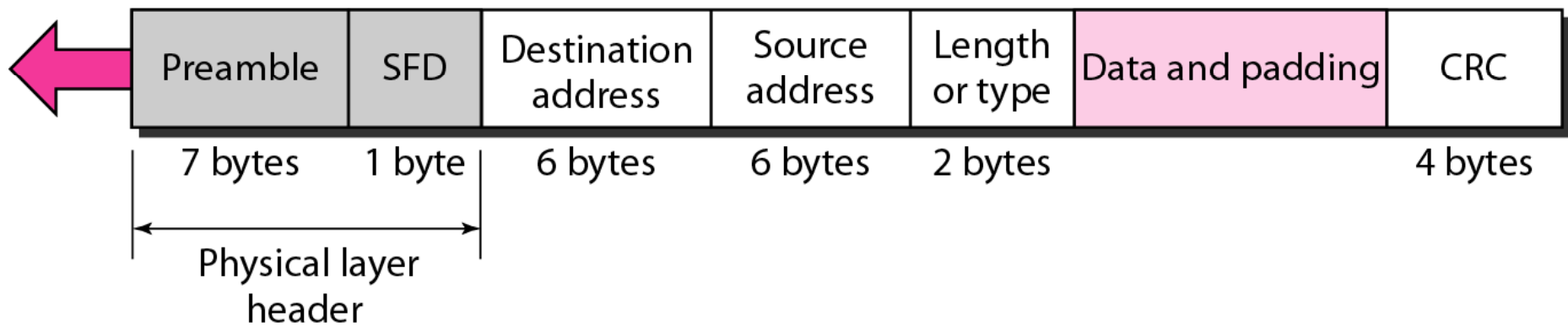
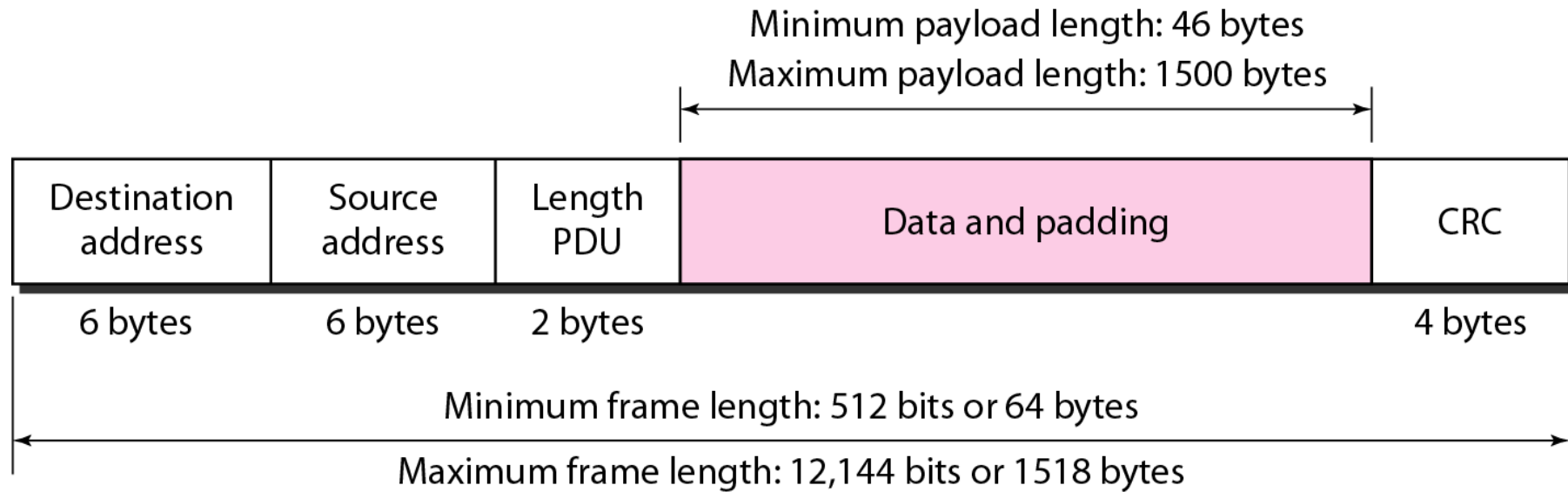

Figure 13.5 *Minimum and maximum lengths*





Note

Frame length:

Minimum: 64 bytes (512 bits)

Maximum: 1518 bytes (12,144 bits)

Figure 13.6 *Example of an Ethernet address in hexadecimal notation*

06 : 01 : 02 : 01 : 2C : 4B



6 bytes = 12 hex digits = 48 bits

Figure 13.7 *Unicast and multicast addresses*

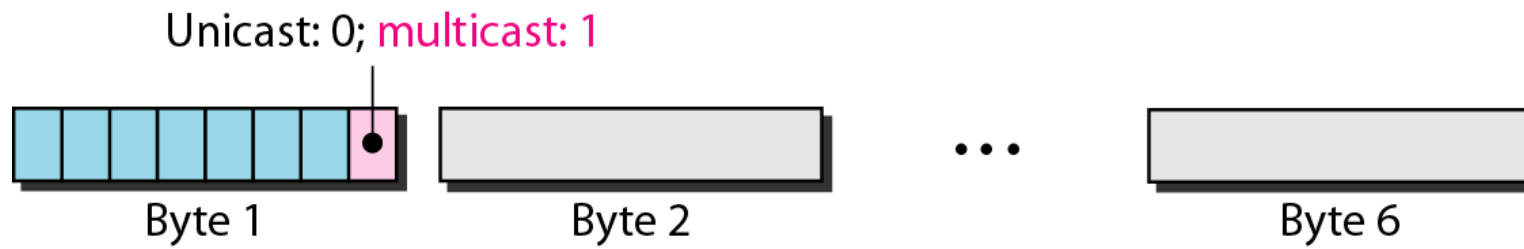



Note

**The least significant bit of the first byte defines the type of address.
If the bit is **0**, the address is unicast;
otherwise, it is multicast.**



Note

The broadcast destination address is a special case of the multicast address in which all bits are 1s.



Example 13.1

Define the type of the following destination addresses:

- a. 4A:30:10:21:10:1A b. 47:20:1B:2E:08:EE*
c. FF:FF:FF:FF:FF:FF

Solution

To find the type of the address, we need to look at the second hexadecimal digit from the left. If it is even, the address is unicast. If it is odd, the address is multicast. If all digits are F's, the address is broadcast. Therefore, we have the following:

- a. This is a unicast address because A in binary is 1010.*
b. This is a multicast address because 7 in binary is 0111.
c. This is a broadcast address because all digits are F's.



Example 13.2

*Show how the address **47:20:1B:2E:08:EE** is sent out on line.*

Solution

The address is sent left-to-right, byte by byte; for each byte, it is sent right-to-left, bit by bit, as shown below:



← 11100010 0000100 11011000 01110100 00010000 01110111

Figure 13.8 *Categories of Standard Ethernet*

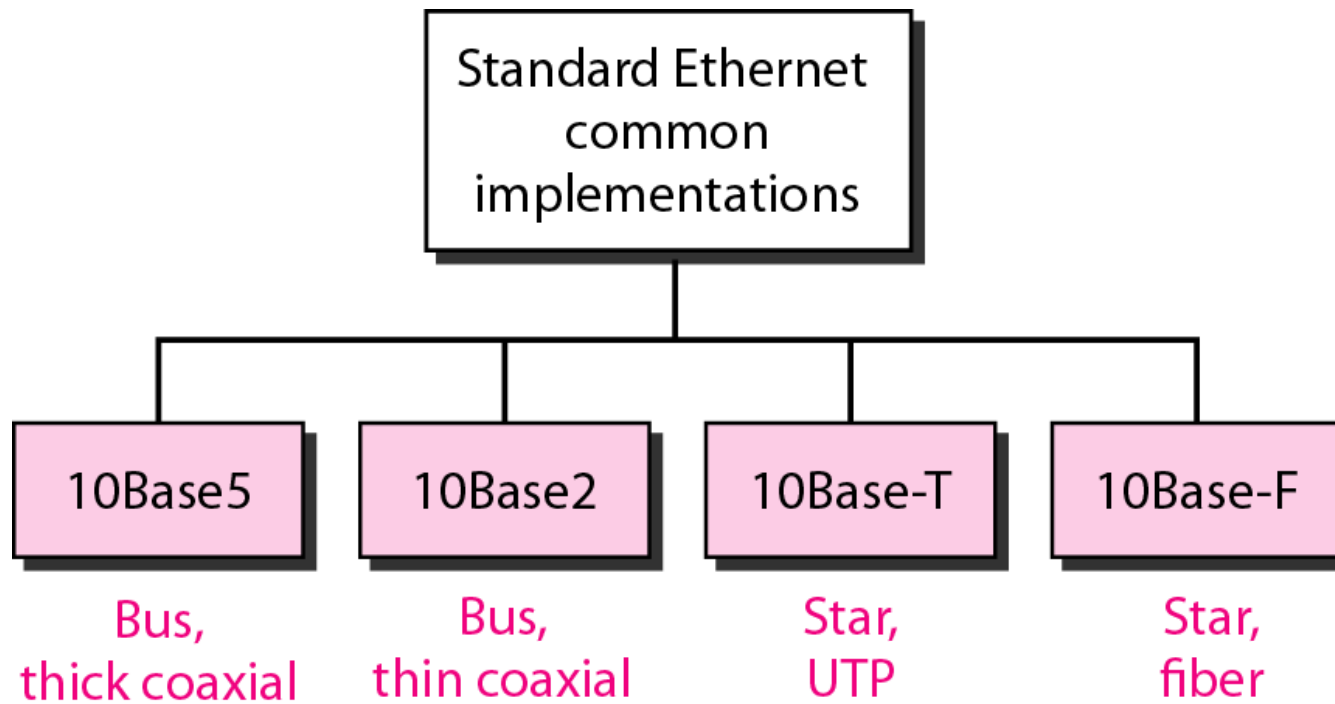

Figure 13.9 *Encoding in a Standard Ethernet implementation*

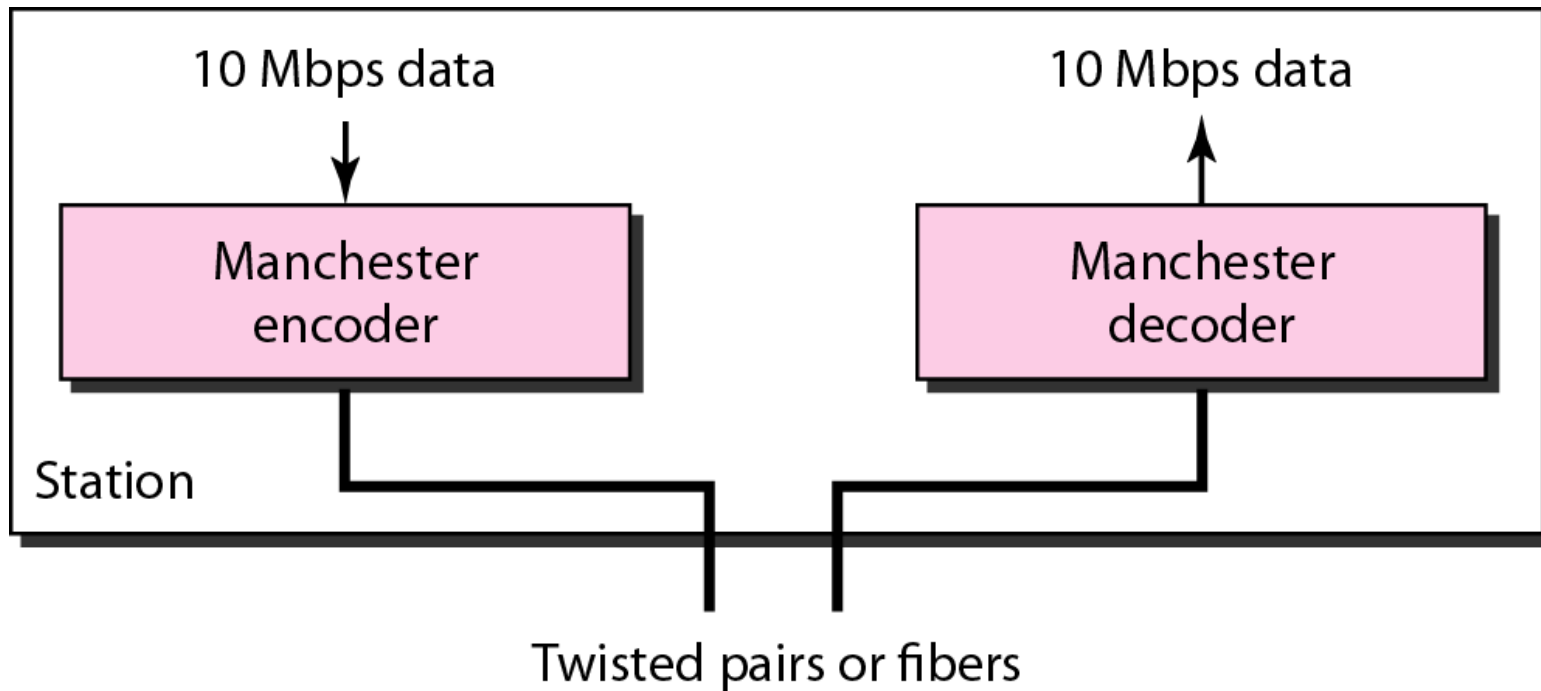

Figure 13.10 *10Base5 implementation*

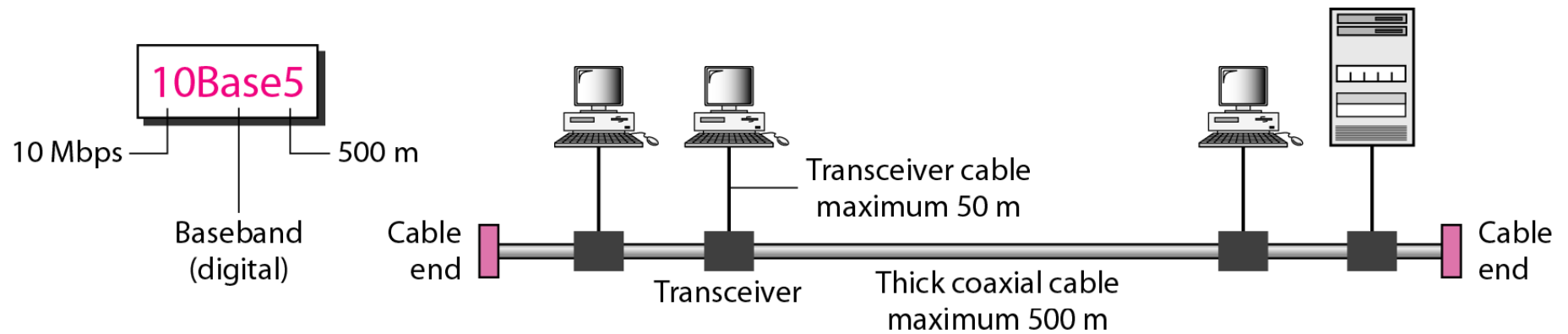

Figure 13.11 *10Base2 implementation*

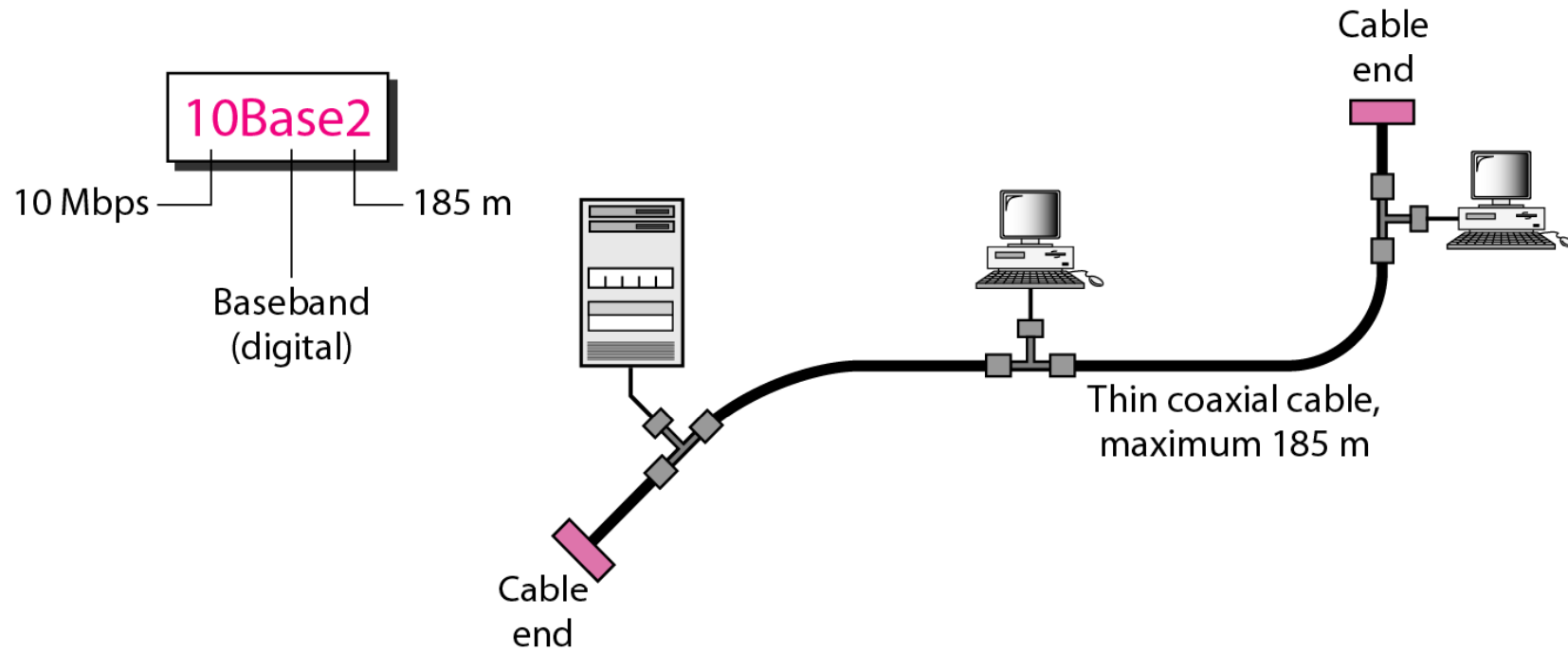

Figure 13.12 *10Base-T implementation*

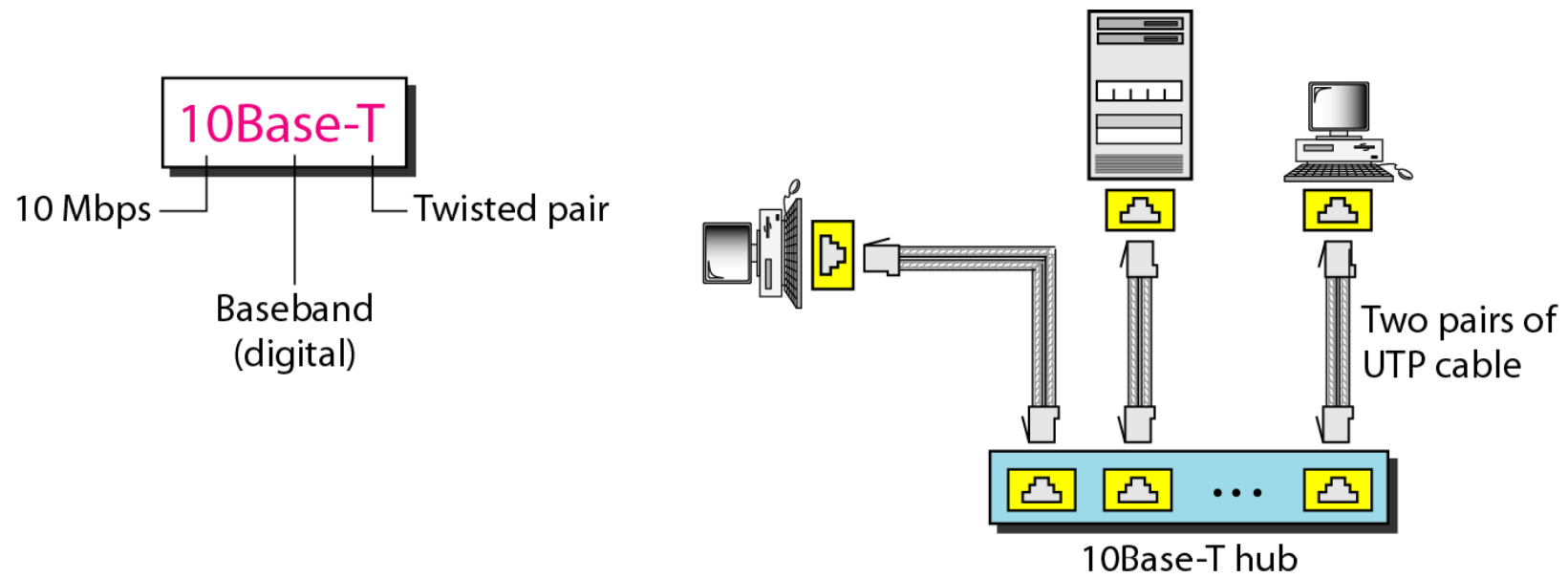

Figure 13.13 *10Base-F implementation*

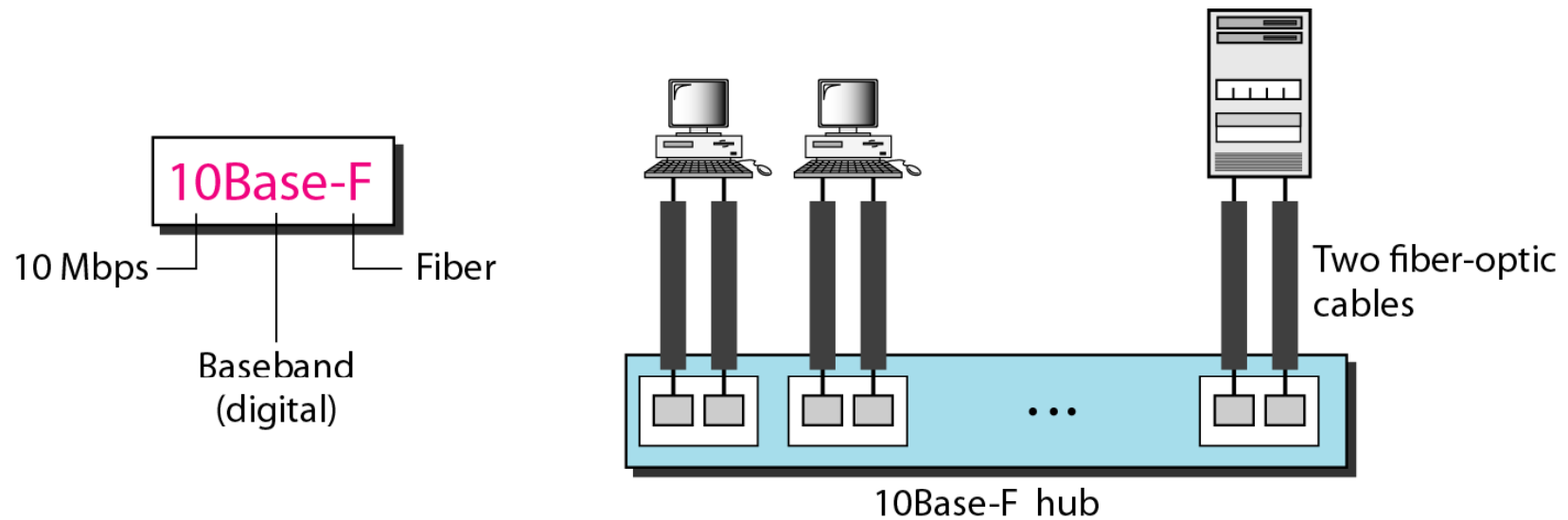

Table 13.1 *Summary of Standard Ethernet implementations*

<i>Characteristics</i>	<i>10Base5</i>	<i>10Base2</i>	<i>10Base-T</i>	<i>10Base-F</i>
Media	Thick coaxial cable	Thin coaxial cable	2 UTP	2 Fiber
Maximum length	500 m	185 m	100 m	2000 m
Line encoding	Manchester	Manchester	Manchester	Manchester

13-3 CHANGES IN THE STANDARD

The 10-Mbps Standard Ethernet has gone through several changes before moving to the higher data rates. These changes actually opened the road to the evolution of the Ethernet to become compatible with other high-data-rate LANs.

Topics discussed in this section:

Bridged Ethernet

Switched Ethernet

Full-Duplex Ethernet

Figure 13.14 *Sharing bandwidth*

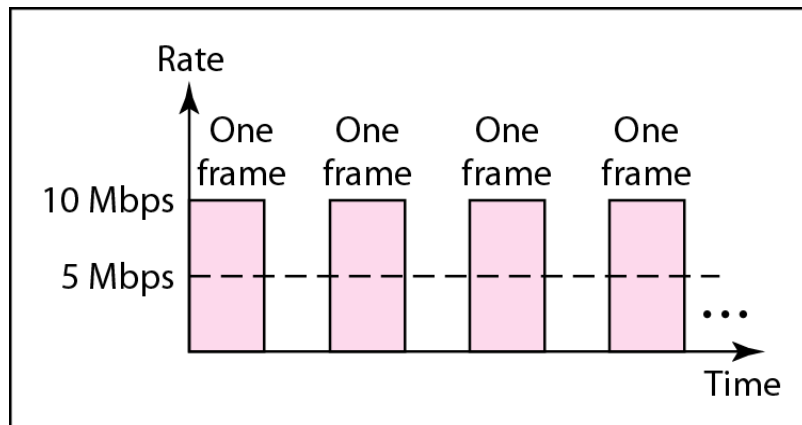

a. First station

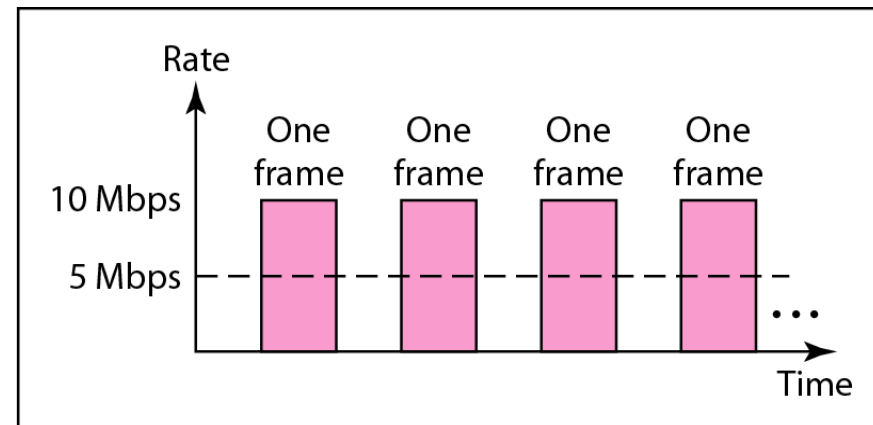

b. Second station

Figure 13.15 *A network with and without a bridge*

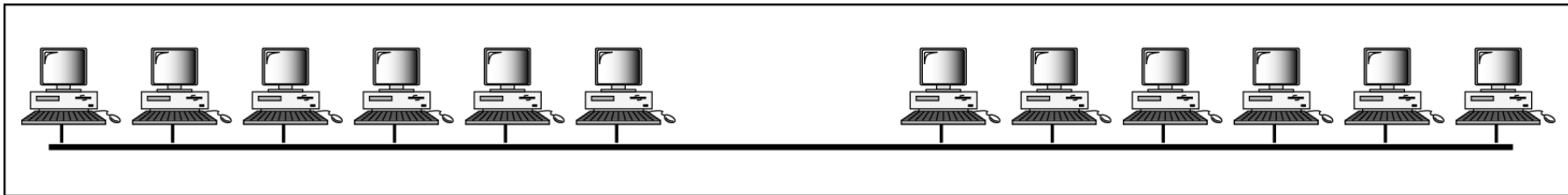

a. Without bridging

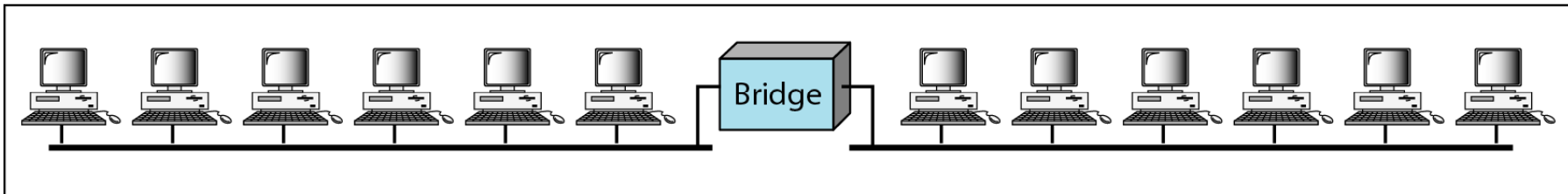

b. With bridging

Figure 13.16 *Collision domains in an unbridged network and a bridged network*

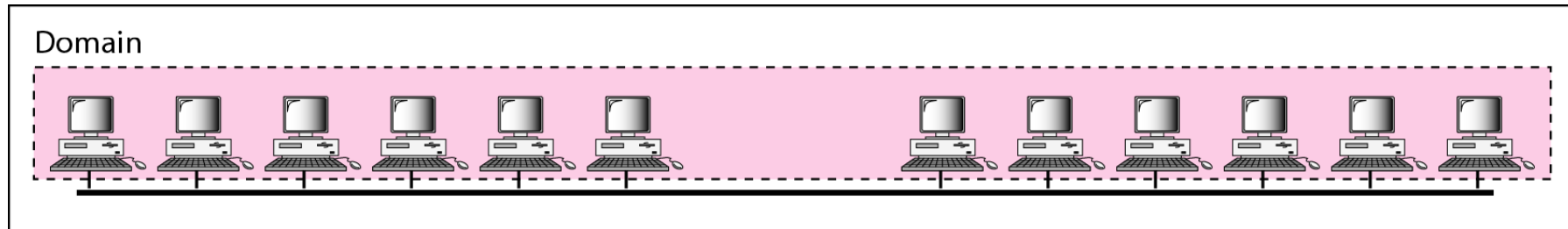

a. Without bridging

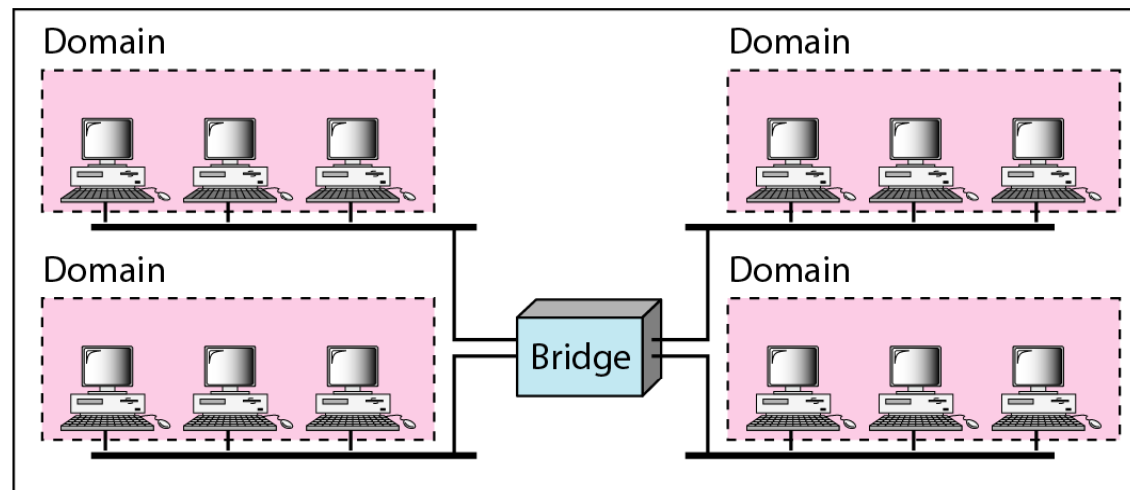

b. With bridging

Figure 13.17 *Switched Ethernet*

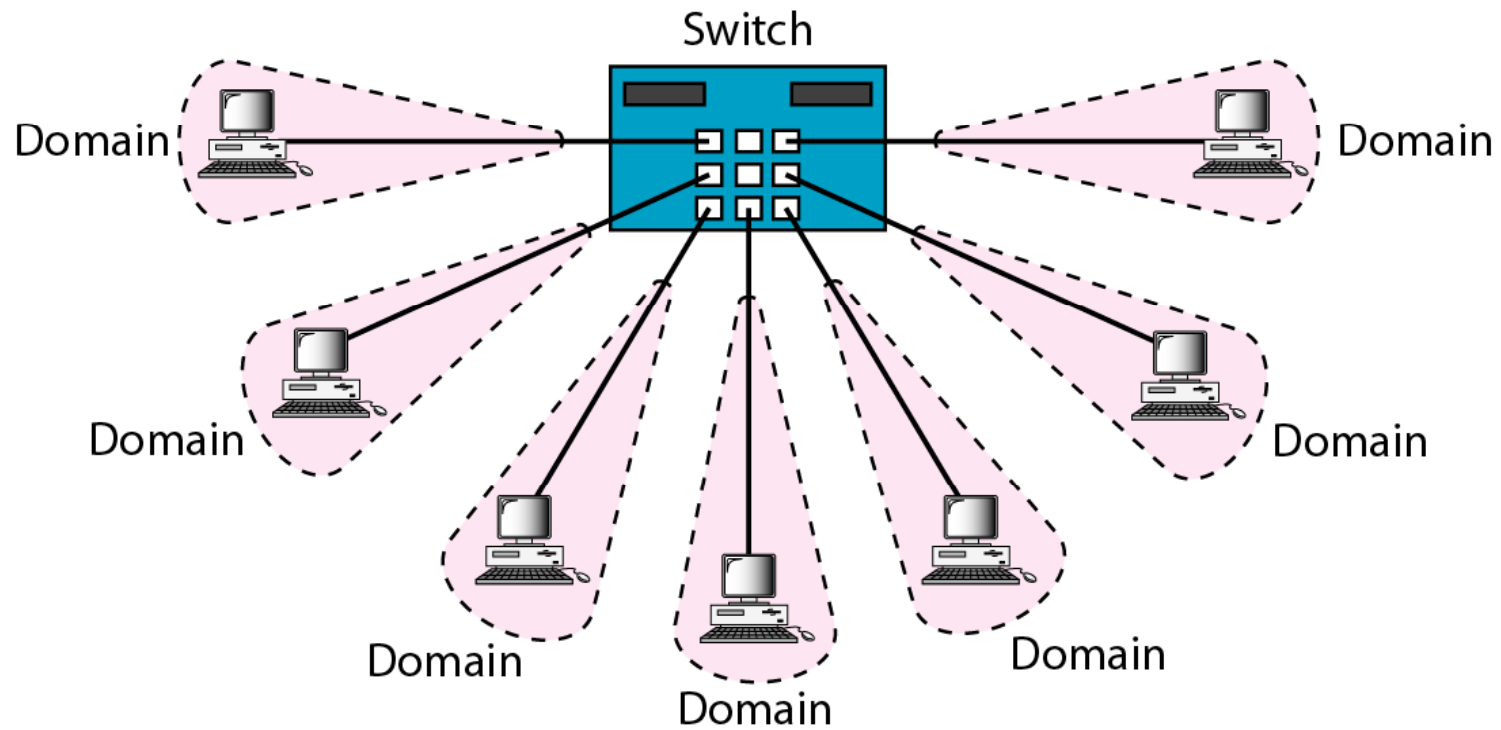
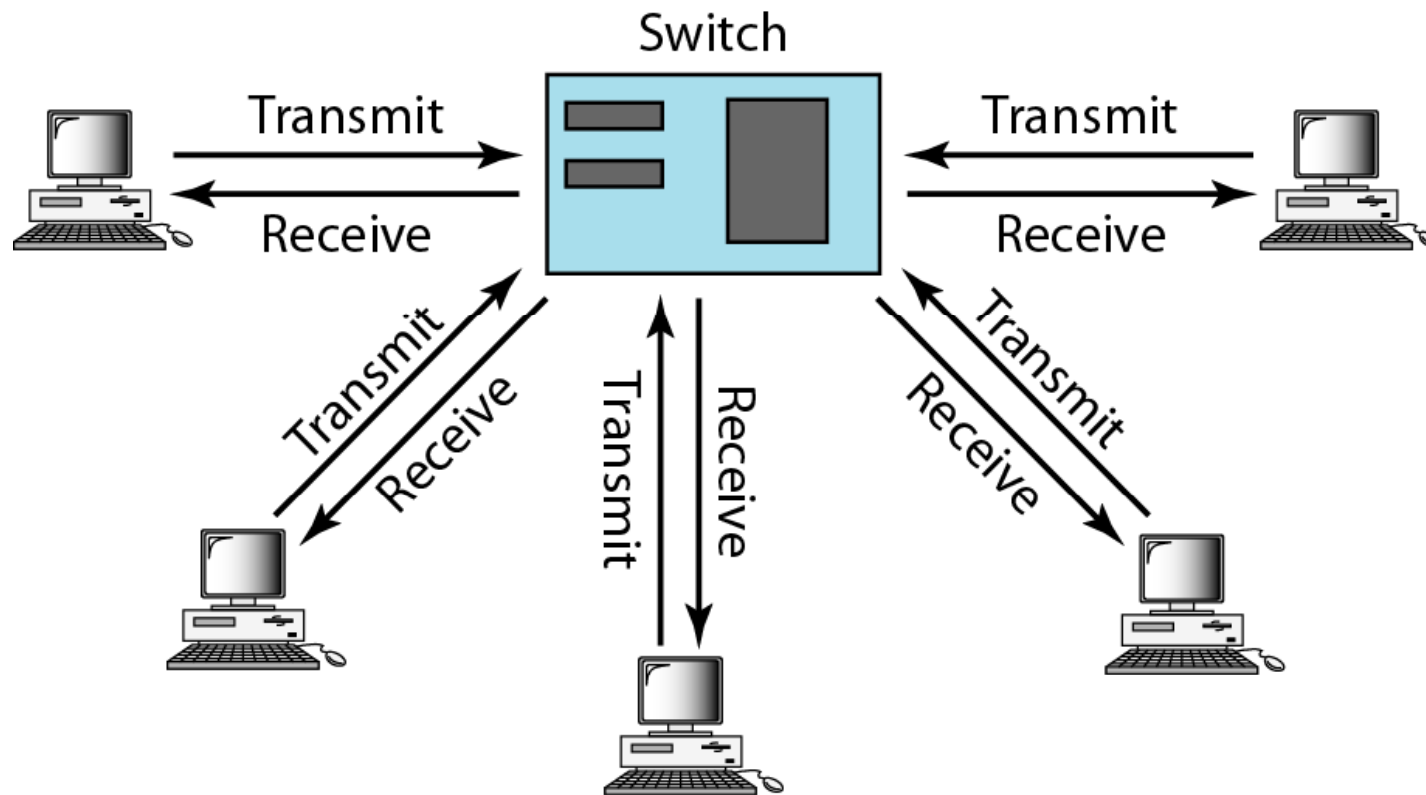

Figure 13.18 *Full-duplex switched Ethernet*



13-4 FAST ETHERNET

Fast Ethernet was designed to compete with LAN protocols such as FDDI or Fiber Channel. IEEE created Fast Ethernet under the name 802.3u. Fast Ethernet is backward-compatible with Standard Ethernet, but it can transmit data 10 times faster at a rate of 100 Mbps.

Topics discussed in this section:

MAC Sublayer

Physical Layer

Figure 13.19 *Fast Ethernet topology*

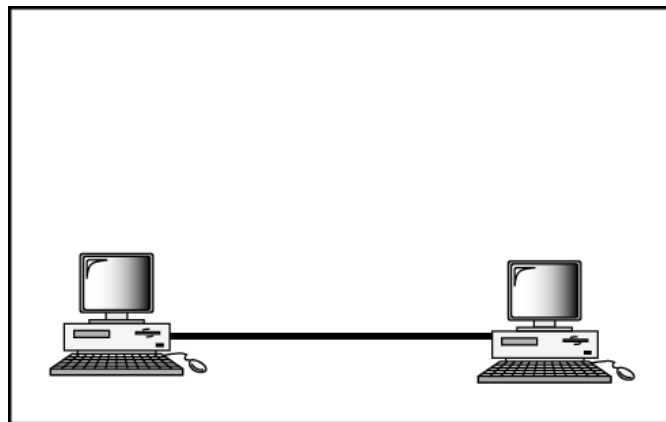

a. Point-to-point

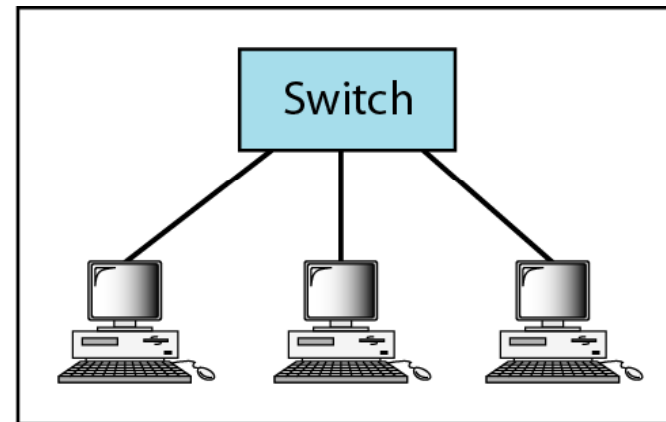

b. Star

Figure 13.20 *Fast Ethernet implementations*

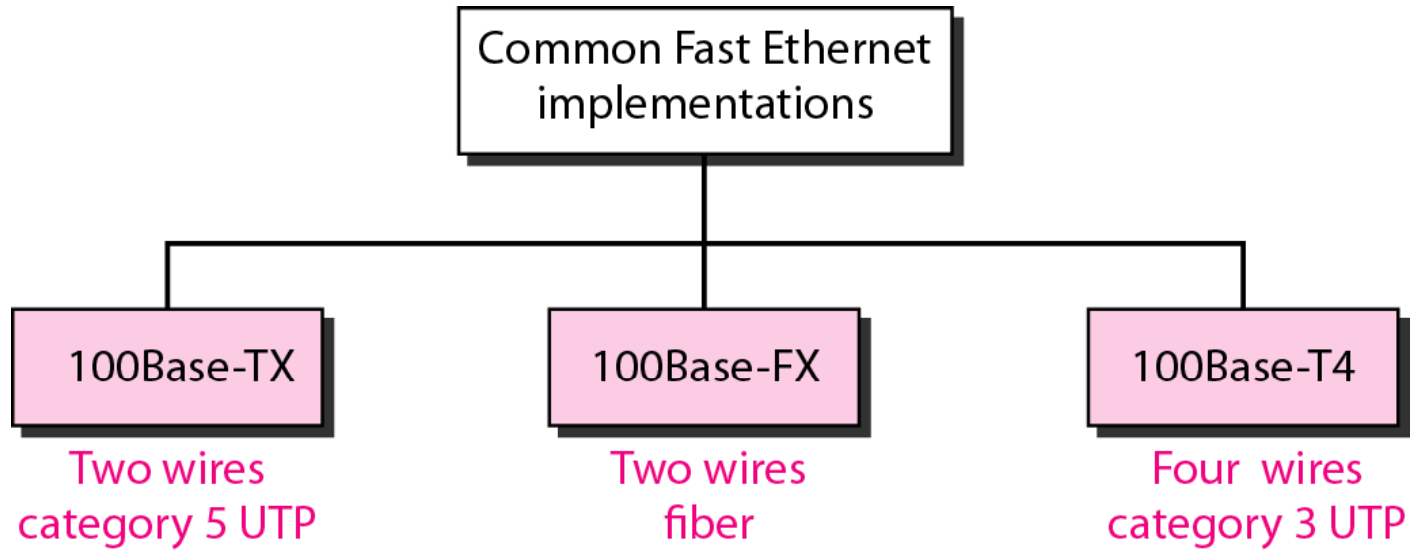

Figure 13.21 *Encoding for Fast Ethernet implementation*

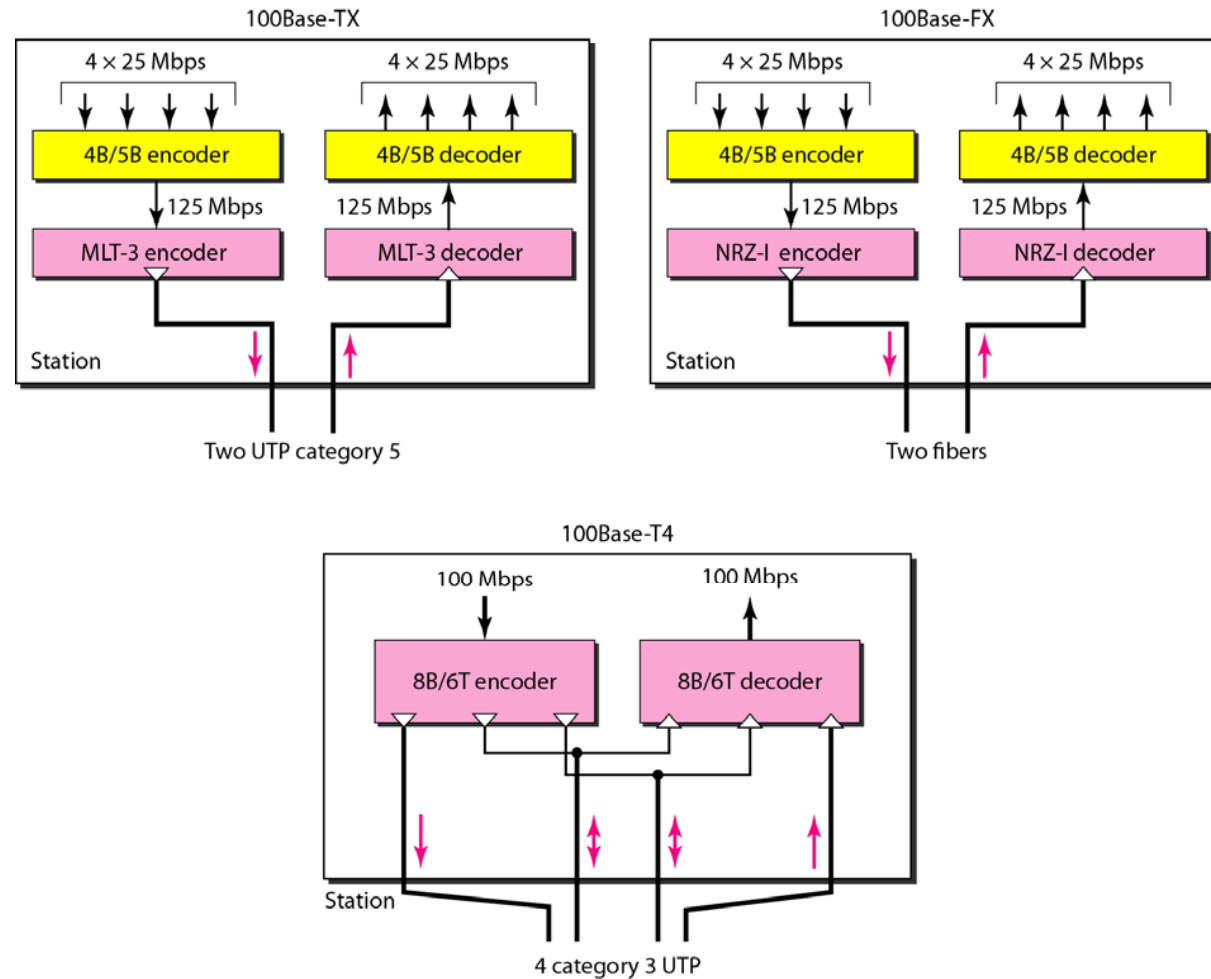

Table 13.2 *Summary of Fast Ethernet implementations*

<i>Characteristics</i>	<i>100Base-TX</i>	<i>100Base-FX</i>	<i>100Base-T4</i>
Media	Cat 5 UTP or STP	Fiber	Cat 4 UTP
Number of wires	2	2	4
Maximum length	100 m	100 m	100 m
Block encoding	4B/5B	4B/5B	
Line encoding	MLT-3	NRZ-I	8B/6T

13-5 GIGABIT ETHERNET

The need for an even higher data rate resulted in the design of the Gigabit Ethernet protocol (1000 Mbps). The IEEE committee calls the standard 802.3z.

Topics discussed in this section:

MAC Sublayer

Physical Layer

Ten-Gigabit Ethernet



Note

In the full-duplex mode of Gigabit Ethernet, there is no collision; the maximum length of the cable is determined by the signal attenuation in the cable.

Figure 13.22 *Topologies of Gigabit Ethernet*

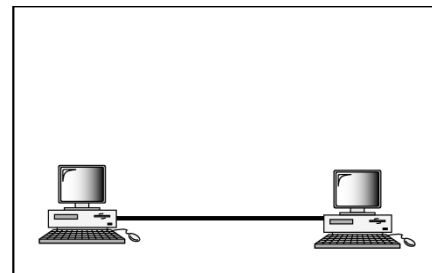

a. Point-to-point

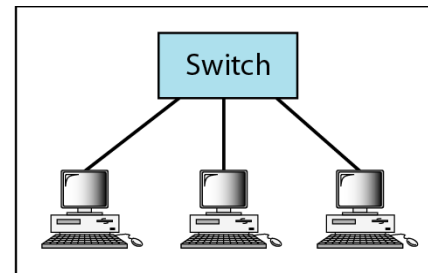

b. Star

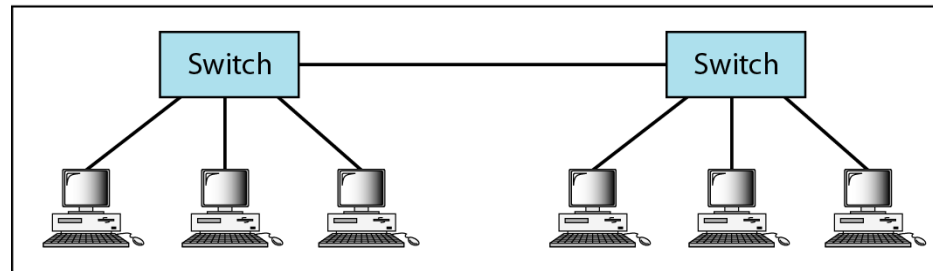

c. Two stars

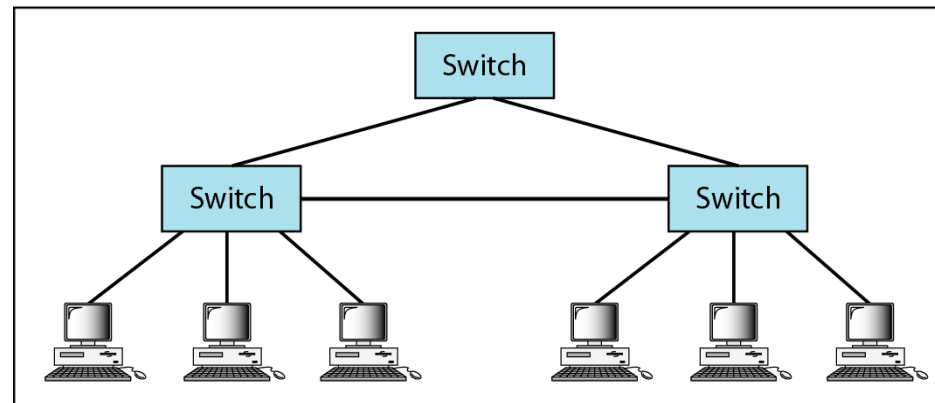

d. Hierarchy of stars

Figure 13.23 *Gigabit Ethernet implementations*

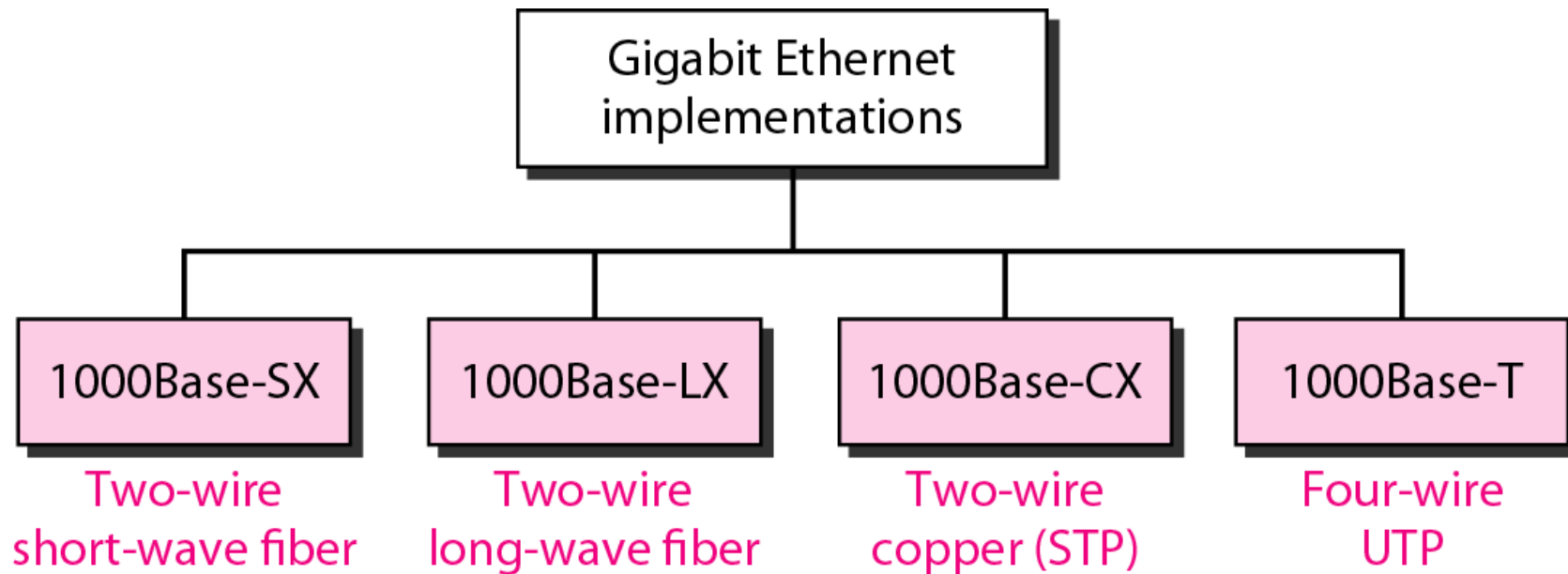

Figure 13.24 *Encoding in Gigabit Ethernet implementations*

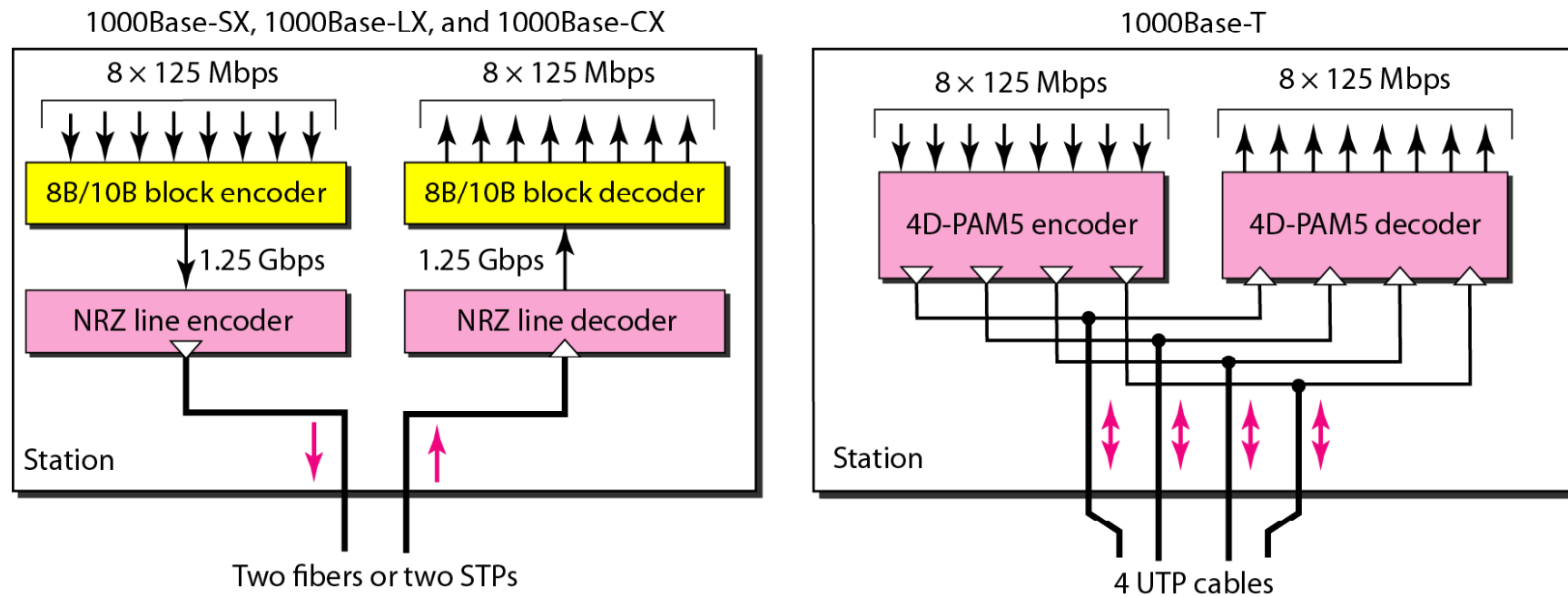

Table 13.3 *Summary of Gigabit Ethernet implementations*

<i>Characteristics</i>	<i>1000Base-SX</i>	<i>1000Base-LX</i>	<i>1000Base-CX</i>	<i>1000Base-T</i>
Media	Fiber short-wave	Fiber long-wave	STP	Cat 5 UTP
Number of wires	2	2	2	4
Maximum length	550 m	5000 m	25 m	100 m
Block encoding	8B/10B	8B/10B	8B/10B	
Line encoding	NRZ	NRZ	NRZ	4D-PAM5

Table 13.4 *Summary of Ten-Gigabit Ethernet implementations*

<i>Characteristics</i>	<i>10GBase-S</i>	<i>10GBase-L</i>	<i>10GBase-E</i>
Media	Short-wave 850-nm multimode	Long-wave 1310-nm single mode	Extended 1550-nm single mode
Maximum length	300 m	10 km	40 km