

Reg No.: \_\_\_\_\_

Name: \_\_\_\_\_

**APJ ABDUL KALAM TECHNOLOGICAL UNIVERSITY**  
THIRD SEMESTER B.TECH DEGREE EXAMINATION, DECEMBER 2017

**Course Code: ME201**

**Course Name: MECHANICS OF SOLIDS (ME,MP,MA,MT,AU,PE,SF)**

Max. Marks: 100

Duration: 3 Hours

**PART A**

*Answer any three full questions, each carries 10marks.*

- |   |                                                                                                                                                                                                                                                                                                                                                                                                                                | Marks |
|---|--------------------------------------------------------------------------------------------------------------------------------------------------------------------------------------------------------------------------------------------------------------------------------------------------------------------------------------------------------------------------------------------------------------------------------|-------|
| 1 | a) Explain Hooke's law for linearly elastic isotropic material.                                                                                                                                                                                                                                                                                                                                                                | (3)   |
|   | b) A steel tie rod 40 mm in diameter and 2 m long is subjected to a pull of 80kN. To what length the bar should be bored centrally so that the total extension will increase by 20% for the same pull, the bore being 20 mm in diameter. Take $E = 2 \times 10^5 \text{ N/mm}^2$ .                                                                                                                                             | (7)   |
| 2 | a) Define the terms resilience and proof resilience.                                                                                                                                                                                                                                                                                                                                                                           | (3)   |
|   | b) A copper strip $20 \times 2.5 \text{ mm}^2$ in section is held between two strips of steel each $20 \times 2.5 \text{ mm}^2$ in section. Find the stresses in steel and copper due to temperature rise of $6^\circ\text{C}$ . Take $\alpha_s = 1.2 \times 10^{-5} / ^\circ\text{C}$ , $\alpha_c = 1.85 \times 10^{-5} / ^\circ\text{C}$ , $E_s = 2 \times 10^5 \text{ N/mm}^2$ and $E_c = 1.2 \times 10^5 \text{ N/mm}^2$ . | (7)   |
| 3 | a) Define Poisson's ratio.                                                                                                                                                                                                                                                                                                                                                                                                     | (2)   |
|   | b) A bar of circular cross section 20 mm diameter is subjected to an axial compressive load of 100 kN. The increase in diameter is found to be 0.0082 mm. Calculate the values of Poisson's ratio and modulus of elasticity. Take modulus of rigidity as $8 \times 10^4 \text{ N/mm}^2$ .                                                                                                                                      | (8)   |
| 4 | A solid aluminium shaft 1 m long and 50 mm diameter is to be replaced by a tubular steel shaft of the same length and the same outside diameter such that each of the two shafts could have the same angle of twist per unit torsional moment over the total length. What must the inner diameter of the tubular steel shaft be? Modulus of rigidity of the steel is three times that of aluminium.                            | (10)  |

**PART B**

*Answer any three full questions, each carries 10marks.*

- |   |                                                                                                                                                                                                                                                      |      |
|---|------------------------------------------------------------------------------------------------------------------------------------------------------------------------------------------------------------------------------------------------------|------|
| 5 | A simply supported beam ABC with supports at A and B, 5m apart with an overhang BC 2m long carries a uniformly distributed load of 20 kN/m over the whole length as shown in Fig.1. Draw S.F and B.M diagrams and locate the point of contraflexure. | (10) |
|---|------------------------------------------------------------------------------------------------------------------------------------------------------------------------------------------------------------------------------------------------------|------|

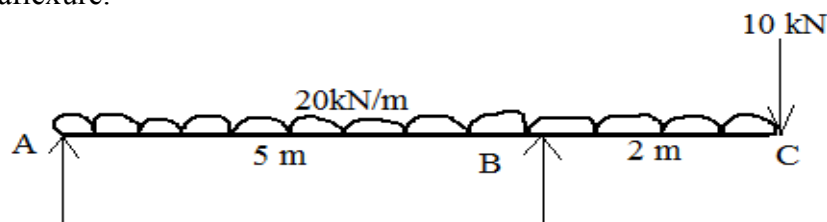

**Fig. 1**

- |   |                                                                                                                                                                                                                                                                                                                                                                       |     |
|---|-----------------------------------------------------------------------------------------------------------------------------------------------------------------------------------------------------------------------------------------------------------------------------------------------------------------------------------------------------------------------|-----|
| 6 | a) What do you understand by the term 'point of inflection'?                                                                                                                                                                                                                                                                                                          | (2) |
|   | b) A simply supported beam of length 10 m carries a uniformly distributed load of 10 kN/m over a span length of 5 m from the left support. A point load of 15 kN and a moment of 10 kN-m are acting on the beam at a distance of 6.5 m and 8 m respectively from the left support. Draw the SF and BM diagrams. Find out the maximum bending moment and its location. | (8) |

- 7 Derive from fundamentals pure bending equation  $\frac{M}{I} = \frac{f}{y} = \frac{E}{R}$ . Also state the (10)  
important assumptions.
- 8 The T shaped cross section of a beam shown in Fig. 2 is subjected to vertical shear (10)  
force of 100 kN. Calculate the shear stress at the neutral axis and at the junction of  
the web and the flange. Moment of inertia about the horizontal neutral axis is  $1.134$   
 $\times 10^8 \text{ mm}^4$ .

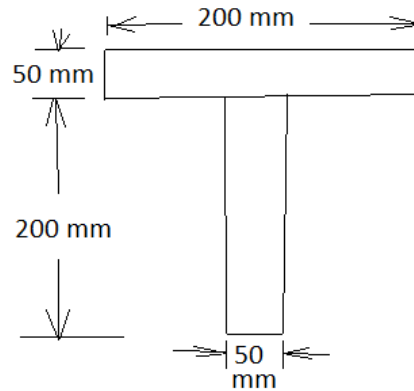

Fig. 2

## PART C

*Answer any four full questions, each carries 10marks.*

- 9 A horizontal girder of steel having uniform section is 14 m long and is simply (10)  
supported at its ends. It carries concentrated loads of 120 kN and 80 kN at two  
points 3 m and 4.5 m from the two ends respectively.  $I$  for the section of the girder  
is  $16 \times 10^8 \text{ mm}^4$  and  $E_s = 210 \text{ kN/mm}^2$ . Calculate the deflection of the girder at  
points under the two loads and maximum deflection using Macaulay's method.
- 10 The principal stresses at a point are  $200 \text{ N/mm}^2$  and  $80 \text{ N/mm}^2$  both tensile. Find (10)  
the normal, tangential and resultant stresses on a plane inclined at  $55^\circ$  to the  
direction of the major principal stress.
- 11 A cantilever of uniform section has a length of  $AB = l$ , A is the free end and carries (10)  
a point load  $W$ , while B is the fixed end. Find the deflection at a point C distant  $\frac{l}{4}$   
from the free end A.
- 12 At a point in a bracket the stresses on two mutually perpendicular planes are (10)  
 $120 \text{ N/mm}^2$  and  $60 \text{ N/mm}^2$  both tensile. The shear stress across these planes is  $30$   
 $\text{N/mm}^2$ . Find using the Mohr's stress circle the  
(i) principal stresses and  
(ii) maximum shear stress at the point.
- 13 Derive Euler's buckling load for slender columns with one end fixed and other end (10)  
hinged.
- 14 Write short notes on the following: (10)  
i) Stress and strain transformation      ii) Compound stresses  
iii) Rankine's crippling load for a column.

\*\*\*\*\*