

Reg. No. _____

Name: _____

APJ ABDUL KALAM TECHNOLOGICAL UNIVERSITY
SECOND SEMESTER B.TECH DEGREE EXAMINATION, MAY 2017

Course Code: **BE 100**Course Name: **ENGINEERING MECHANICS**

Max. Marks: 100

Duration: 3 Hours

PART A*Answer all questions. 5 marks each.*

1. State and explain the principle of Transmissibility of force with sketches.
2. The x,y,z components of a force are 36kN, -24kN and 24kN respectively. Find the components of this force along the line joining A(1,2,-3) and B(-1,-2,2).
3. Using first theorem of Pappus and Guldinus, find the surface area of a i) Sphere and ii) right circular cone.
4. Distinguish between (i) Static and kinetic frictions,(ii) Sliding friction and rolling friction and (iii) angle of friction and angle of repose.
5. What do you mean by instantaneous centre of rotation? How can it be located for a body moving with combined motion of rotation and translation?
6. What is a seconds's pendulum? Derive expressions for the loss or gain of time due to changes in length of string and gravitational acceleration in the case of a simple pendulum.
7. Define the terms amplitude, period of oscillation and frequency in a simple harmonic motion.
8. State D'Alemberts principle giving equations expressing the above Principle on the motion of a lift moving upwards with an acceleration 'a' m/sec² carrying a weight of 'W' N.

PART B*Answer any 2 questions from each SET.***SET 1***Each question carries 10 marks.*

9. ABCD is a rectangle in which AB=30mm, BC= 20mm. 'E' is the middle point of 'AB'. Forces of magnitude 16,14,18,8,10 and 20N act along 'AB', 'BC', 'CD', 'DA', 'EC' and 'DE' respectively. Find the magnitude, direction and position with respect to 'ABCD' of single force to keep the body in equilibrium. 'B' is to right of 'A' and taken in anticlockwise direction.
10. a. A cylindrical road roller of weight 1000N and radius 30 cm is pulled by a force 'F' through the centre of the wheel. While moving it comes across an obstacle of height 15 cm. Calculate the least force 'F' required to cross the obstacle . (5)
- b. A force acts at the origin of a co-ordinate system in a direction defined by the angles $\alpha_x=69.3^0$ and $\alpha_z=57.9^0$. Knowing that the 'Y' component of the force is -174N, determine the (i) angle α_y and (ii) the other components and the magnitude of the force. (5)

11.

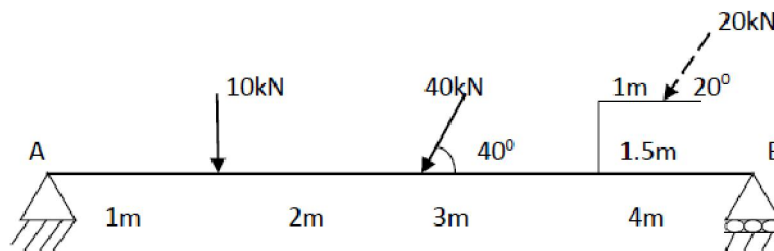

Determine the reactions at supports for the beam. (10)

SET II

Each question carries 10 marks.

12. a. Calculate the moment of inertia and radius of gyration about X axis for the sectioned area.

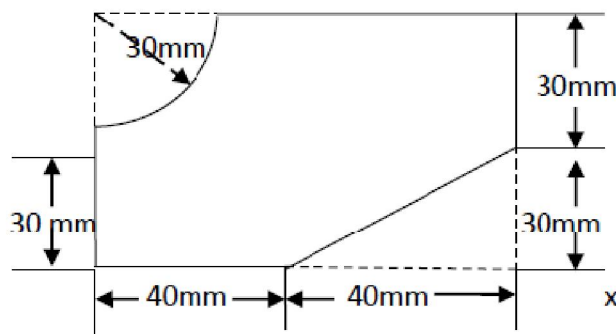

(7)

- b. An area 'A' has the following properties, $I_x = 6.4 \times 10^6 \text{ mm}^4$, $I_y = 16 \times 10^6 \text{ mm}^4$ and $I_{xy} = 6.4 \times 10^6 \text{ mm}^4$. Calculate maximum and minimum principal moment of inertia. (3)
13. a. A ladder 5 m long and weighing 260 N is placed against a vertical wall at an inclination of 30° with wall. A man weighing 780 N climbs the ladder. When he is at a distance of 1.64 m along the ladder from lower end, the ladder slips, What is the coefficient of friction assuming it to be same for all contact surfaces? (5)
- b. A simply supported beam of span 5 m is loaded with a concentrated load of 4kN at a distance of 1 m from right end. The beam is also loaded with a uniformly distributed load of 2kN/m length over a distance of 2m from the left end of the beam. Find the reactions at the supports of the beam using principle of virtual work. (5)
14. a. Explain with sketches how the forces involved in the lifting of a load by a wedge are analysed. (5)
- b. Determine the product of inertia of the sectioned area about the X-Y axis. (5)

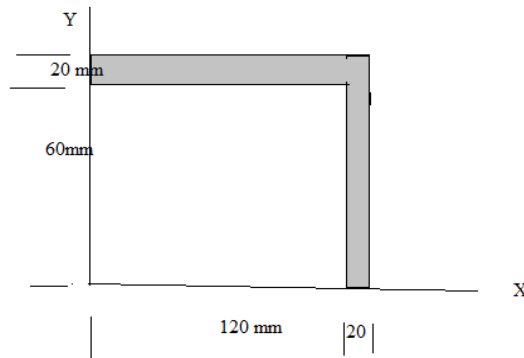

SET III

Each question carries 10 marks.

15. a. A lift is ascending with an acceleration of 0.6m/sec^2 . A man holds a spring balance from which a parcel weighing 13.6 N is hung. What will be the reading in the spring balance? (3)
- b. The crank 'OA' of a reciprocating engine mechanism is of length 15 cm and rotating at 600 rpm . The connecting rod 'AB' is 70cm long. Find the (i) angular velocity of the connecting rod, (ii) velocity of the piston 'B' and (iii) the velocity at a point 'C' on the connecting rod at a distance 50cm from the piston end when the crank makes an angle 45° . (7)
16. a. In a system the amplitude of the motion is 1.6m and time period is 4 sec . find the time required for the particle in passing between points which are at a distance of 1.2m and 0.6m from the centre of force and are on the same side of it. (7)
- b. A roller of radius 12 cm rides between two horizontal bars moving in opposite directions with velocities 2.88 m/sec and 1.92 m/sec . Calculate the distance defining the position of the path of the instantaneous centre of rotation of the roller. Assume no slip at points of contacts. (3)
17. a. A tray of mass 'm' is mounted on three identical springs as shown. The period of vibration of empty tray is 0.5 sec . After placing a mass of 1.5 kg on the tray, the period was observed to be 0.6 sec . Find the mass of the tray and stiffness of each spring. (5)

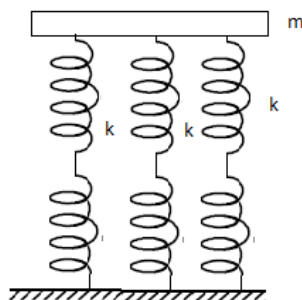

- b. A body performing simple harmonic motion completes 8 oscillations in one minute. The velocity of the body is half the maximum velocity at a distance of 12 cm from the centre. Determine the amplitude and maximum acceleration. (5)