

APJ ABDUL KALAM TECHNOLOGICAL UNIVERSITY

Fifth Semester B.Tech Degree Regular and Supplementary Examination December 2020

Course Code: EE303**Course Name: LINEAR CONTROL SYSTEMS**

Max. Marks: 100

Duration: 3 Hours

*(Graph sheets and semi-log graph sheets will be provided)***PART A***Answer all questions, each carries 5 marks.*

Marks

- 1 Obtain the transfer function of series RLC circuit. Take voltage across capacitor as the output voltage. (5)
- 2 Explain the working principle of a synchro used as an error detector in a control circuit. (5)
- 3 Consider a unity feedback system with transfer function $G(s) = \frac{50K}{s(s+5)(s+2)}$. Find the velocity error constant of the system with $K=1$. What will be the velocity error constant of the same system after adding a zero at $s = -4$? (5)
- 4 How is the root locus technique useful in the analysis of a control system? (5)
- 5 How gain margin and phase margin values help in studying relative stability of a system? (5)
- 6 The asymptotic bode plot of a transfer function is shown in figure. Obtain the transfer function $G(s)$ corresponding to this bode plot. (5)

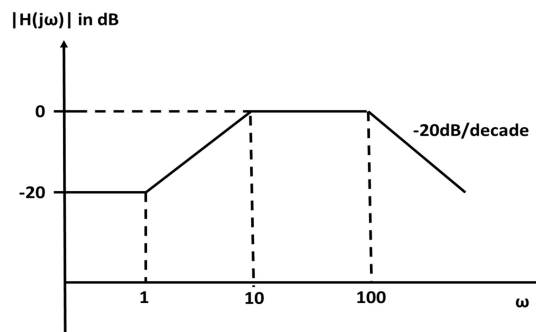

- 7 Write a short note on Nichols chart. (5)

- 8 Differentiate between minimum phase and non-minimum phase system with suitable examples (5)

PART B

Answer any two full questions, each carries 10 marks.

- 9 a) Obtain the overall transfer function of the system shown in figure using block reduction techniques. (5)

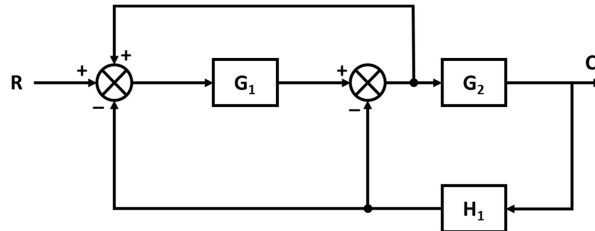

- b) Obtain the transfer function of an armature-controlled DC motor. (5)
- 10 a) For the mechanical system shown in figure write the equilibrium equations and obtain electrical analogous circuit using force-voltage analogy. (5)

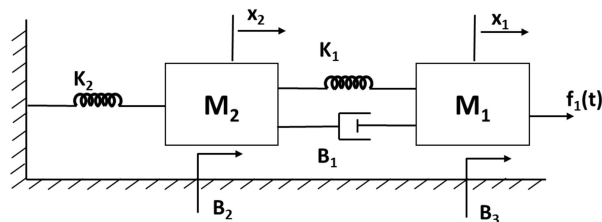

- b) For a control system with negative feedback $G(s) = \frac{a}{s^2}$, $H(s) = 1 + bs$. Find the value of a and b so that peak overshoot = 6% and peak time = 1 sec when a unit step is applied to the system. (5)
- 11 a) For the system shown in figure obtain the closed loop transfer function $C(s)/R(s)$ using Mason's gain formula. (6)

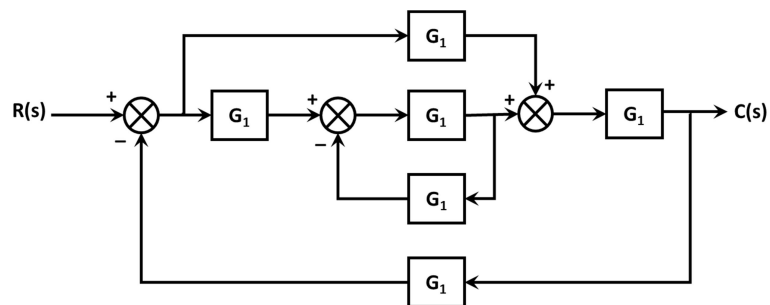

- b) Briefly explain the effect of damping ratio on time response of a second order system. (4)

PART C

Answer any two full questions, each carries 10 marks.

- 12 a) Using Routh-Hurwitz criterion find the number of poles on the left half of s-plane and comment on the stability of the system with characteristic equation $F(s) = s^6 + 4s^5 + 12s^4 + 16s^3 + 41s^2 + 36s + 72$. (6)
- b) The closed loop transfer function of a unity feedback system is given by $\frac{C(s)}{R(s)} = \frac{Ks+\beta}{s^2+\alpha s+\beta}$. Determine the steady state error for unit ramp input. (4)
- 13 a) Sketch root locus for a system with $G(s)H(s) = \frac{K}{s(s+2)(s^2+4s+8)}$. Find the value of K for sustained oscillation. (10)
- 14 a) Write a note on angle and magnitude condition of root locus. (5)
- b) For a unity feedback system with open loop transfer function $G(s) = \frac{K(s+0.5)}{s(s+1)^2(s+0.25)}$. Find the value of K so that steady state error is to be kept less than 0.05 for an input of $r(t) = 2 + 5t$. (5)

PART D

Answer any two full questions, each carries 10 marks.

- 15 a) The open-loop transfer function of a unity feedback system is $\frac{2(s+0.25)}{s^2(s+1)(s+0.5)}$. Use asymptotic approach to plot the bode diagram and determine gain margin and phase margin. Also comment about the stability. (10)
- 16 a) Sketch the polar plot of a unity feedback control system having an open loop transfer function $G(s) = \frac{10(s+2)}{s(s+1)(s+3)}$. (6)
- b) What is transportation lag in control system? (4)
- 17 a) State and explain Nyquist stability criterion. (5)
- b) Draw Nyquist plot for the system the open loop transfer function given below $G(s)H(s) = \frac{(s+0.5)}{s^2(s+1)(s+2)}$. Comment on the closed loop stability. (5)
