

CONTENTS

Earth, Environment & Atmospheric Sciences

- 203 Isotherm and Thermodynamic Studies of the Biosorption of Humic Acid from Aqueous Solution by Pine Sawdust based Activated Charcoal**
- Activated charcoal was prepared from pine tree sawdust by chemical activation by means of phosphoric acid (PSDP) that was used for Humic acid bio sorption from aqueous medium. The influence of humic acid initial concentration, sorbent mass, and solution temperature on sorption process was investigated. Langmuir and Freundlich isotherm models were used to analyze the equilibrium sorption data. The maximum adsorption capacities of PSDP obtained from Langmuir were 170.9, 182.1 and 209.6 mg/g at 25°C, 45°C and 65°C, respectively. Humic acid adsorption onto PSDP was spontaneous, favorable at higher temperature and endothermic in nature. Activated charcoal from pine tree sawdust proves to have high capacity adsorptive to natural organic compound (humic acid).

Sobhy M Ibrahim, Mohamed R Hassan & H M H Gad

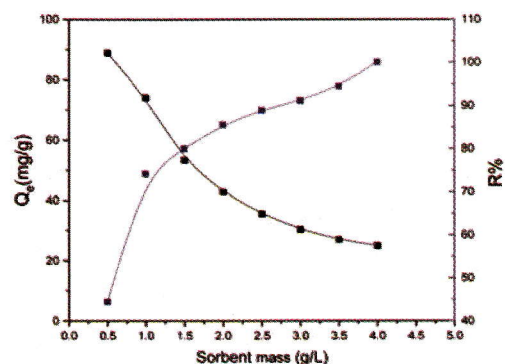

Waste Utilization & Management

- 210 Utilization of Iron Ore Tailings for Brick Manufacture from Donimalai Mines of Karnataka, India**
- The iron tailings were mixed in various proportions with different combinations of cement, sand, and sodium silicate to obtain or value-added product out of iron tailing waste which is suitable for use in the construction industry. Bricks were made using a variety of compositions of iron tailings, Ordinary Portland Cement, sodium silicate, and sand in cuboid mould (9"X 5"X 3"). The bricks were dried for 24 hours, and then kilned at $115 \pm 10^\circ\text{C}$ for 24 hours. Mechanical features such as water absorption, compressive strength, and efflorescence are tested. The maximum compressive strength rating of 8.58 N/mm² was recorded with ratios of 8:2 (Iron tailing and cement). However, in process of making it economical, the ratio of 9:1 has opted and this ratio complies with the requirement of the Indian standard (IS: 1077:1992) of the common burnt clay building bricks. Water absorption for the proposed bricks is less than that of burnt clay bricks. The lower capillary pore can prevent the formation of efflorescence.

Ranjeet Kumar Singh, Debjit Pal, Shailendra Kr Singh, Nimisha Tripathi & Raj S Singh



Computer Science & Information Technology

221 MPP-MLO: Multilevel Parallel Partitioning for Efficiently Matching Large Ontologies

The growing usage of Semantic Web has resulted in an increasing number, size and heterogeneity of ontologies on the web. Therefore, the necessity of ontology matching techniques, which could solve these issues, is highly required. Due to high computational requirements, scalability is always a major concern in ontology matching system. In this work, a partition-based ontology matching system is proposed, which deals with parallel partitioning of the ontologies at multilevel. At first level, the root based ontology partitioning is proposed. Matchable sub-ontology pair is generated using an efficient linguistic matcher (IEI-Sub) to uncover anchors and then based on maximum similarity values, pairs are generated. However, a distributed and parallel approach of MapReduce-based IEI-sub process has been proposed to efficiently handle the anchor discovery process which is highly time-consuming. In second level partitioning, an efficient approach is proposed to form non-overlapping clusters. Extensive experimental evaluation is done by comparing existing approaches with the proposed approach, and the results shows that MPP-MLO turns out to be an efficient and scalable ontology matching system with 58.7% reduction in overall execution time.

Usha Yadav & Neelam Duhan

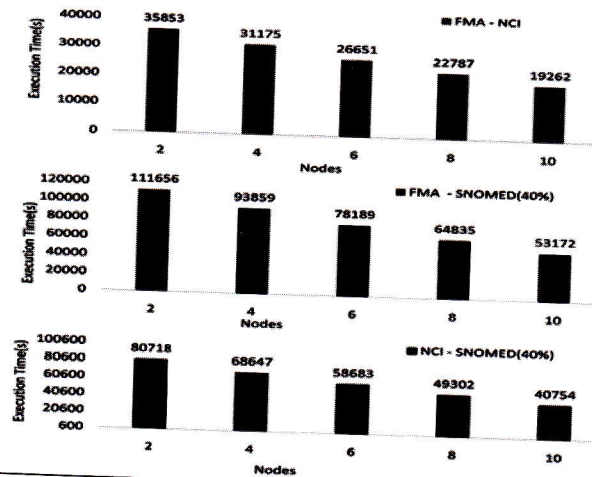

230 ASIC Design of Radix-2,8-Point FFT Processor

In split radix architecture, large sizes Fast Fourier Transforms (FFT) are decomposed into small independent computations to reduce storage burden. Radix-2, 8-point is one the popular choice in split radix for small independent computation. Author propose the FFT processor architecture for this small independent computation i.e. radix-2, 8-point FFT. This paper brief architecture comprising Butterfly Unit (BU), register set and controller. The novelty of this architecture is that it replaces the series of Processing Elements (PE) by single BU. BU computes two halves of the computations concurrently. Arithmetic computations are performed in floating point form to overcome the nonlinearities. All computations are controlled by tailored instruction set. All instructions are of same size and have same execution time.

Prasad Kulkarni, B G Hogade, Vidula Kulkarni & Varsha Turkar

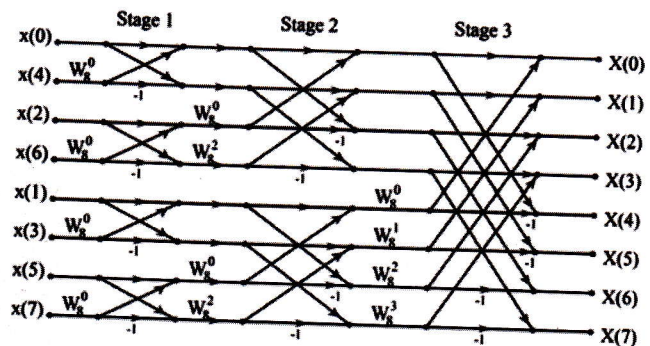

CONTENTS

239 Energy Detector Based Spectrum Sensing Performance Analysis over Fading Environment
 Brijesh Kumar Singh & Mainak Mukhopadhyay

Energy detection approach for sensing of spectrum is an extremely effective method of detection in comparison of other spectrum sensing methods when secondary user lacks adequate knowledge of primary user's channel conditions. Because of multipath propagation and shadowing effects, performance of energy detector employed in a cognitive radio system is severely influenced. In this paper, we have evaluated performance of energy detector over fading environment. Hypothesis testing was utilized for spectrum sensing to find out whether the primary user's signal was available or missing. Performance assessment for spectrum sensing using the energy detector was carried out primarily on the basis of probability of false alarm and probability of detection

245 Reconstruction of Level Cross Sampled Signals using Sparse Signals & Backtracking Iterative Hard Thresholding
 Viswanadham Ravuri, Sudheer Kumar Terlapu & S S Nayak

Industry 4.0 applications involve more number of sensors or Internet of Things (IoT) devices to support automation in the industry. It involves more number of computations to analyze the sensor data collected from several critical parts of the processing units. Sparse signal processing is one which has numerous applications in area of communication and signal processing. This paper presents a novel approach to reduce the computations with the help of level cross sampling (LCS) and a backtracking based iterative hard thresholding (BIHT) algorithm for reconstruction. The process involves, an information signal is converted to a random sparse signal using non-uniform sampling at the transmitter side and then it can be reconstructed back using BIHT algorithm at receiver side. Simulation results exhibit the superior performance of the proposed BIHT reconstruction in comparison with the literature.

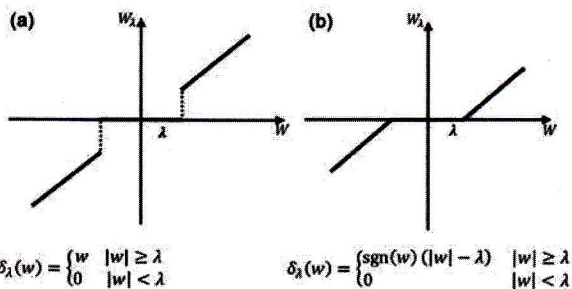

249 Artificial Neural Network Model for Prediction of Students' Success in Learning Programming
 Nebojša Ljubomir Stanković, Marija Dragovan Blagojević, Miloš Željko Papić & Dijana Ivan Karuović

The model for predicting students' success in acquiring programming knowledge and skills is presented in this paper. In order to collect the data needed for development of the model, 159 undergraduate IT students from Faculty of Technical Sciences in Čačak were analyzed. Besides the score on programming knowledge test, the following data were also gathered for each student: high school, the subject he/she took at the entrance exam, size of student's birthplace, average high school grade, points from high school, gender, previous education, existence of IT educational profile in high school, study year, percentage of attendance on classes, reason for enrolment, subjective assessment of preparedness for programming, solving sequential tasks, type of programming student prefers, subjective assessment of preparedness for working in industry, solving tasks with branching and cycle, solving complex tasks, knowledge level, formal education, informal education, Kolb's learning style. In order to predict students' success in learning programming multilayer perceptron was used with backpropagation learning algorithm.

Programming success-calculator

Application gives possibility to predict programming success of students.

Average grade: Gender: Solving sequential tasks:

Students' subjective assessment of whether they are ready to work in the field of programming: Size of town in which students finished highschool: Kolb's learning style:

RESULT: 1-very successful student
(expected achievement >70%)

255 Evolutionary Computing Tools based Design of Elliptical Antenna Array for Amplitude-Position Technique

The work presented in this paper refers to synthesis of elliptical antenna for a desired radiation pattern in which the SLL is optimized using evolutionary computation algorithms like Accelerated Particle Swarm Optimization (APSO), Flower Pollination (FPA) and Antlion Optimization (ALO) algorithms. The amplitude-position technique of synthesis is used in which both amplitude and angular positions of the element on the circumference of the ellipse are determined using the evolutionary computing algorithms. The simulation-based experimentation is carried out for elliptical array of 12 and 20 elements arranged aperiodically with non-uniform amplitude distribution. The Simulations are performed in MATLAB 2019 and SLL are obtained from the corresponding radiation pattern for analysis.

B S S V Ramesh Babu, P S R Chowdary & Satyasis Mishra

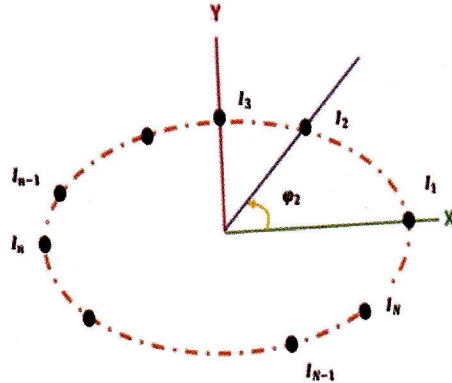

260 Weight Based Deduplication for Minimizing Data Replication in Public Cloud Storage

The approach to optimize the data replication in public cloud storage when targeting the multiple instances is one of the challenging issues to process the text data. The amount of digital data has been increasing exponentially. There is a need to reduce the amount of storage space by storing the data efficiently. In cloud storage environment, the data replication provides high availability with fault tolerance system. An effective approach of deduplication system using weight based method is proposed at the target level in order to reduce the unwanted storage spaces in cloud. Storage space can be efficiently utilized by removing the unpopular files from the secondary servers. Target level consumes less processing power than source level deduplication. Multiple input text documents are stored into dropbox cloud. The top text features are detected using the Term Frequency (TF) and Named Entity Recognition (NER) and they are stored in text database.

E Pugazhendi, M R Sumalatha & Lakshmi Harika P

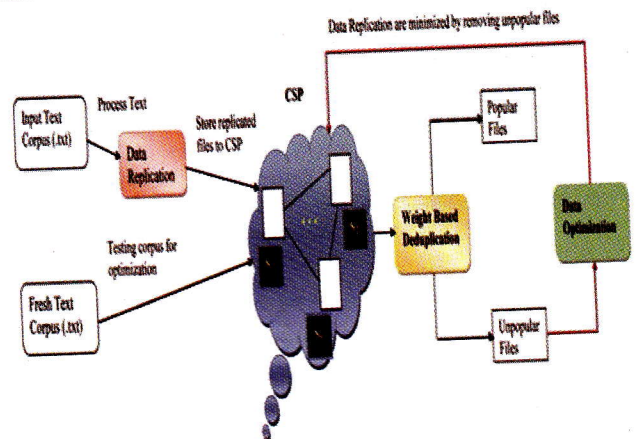

CONTENTS

270 Proposed Framework for Dealing COVID-19 Pandemic Using Blockchain Technology

The production and distribution of COVID-19 testing kits is an urgent and increasingly worldwide requirement, due to the ongoing pandemic. The accuracy of the kit is critically important and to save the world from the faulty kit becomes an issue. The kit before use has to be approved by an authorized medical research agency like US-FDA, ICMR, etc. In this paper, we proposed a framework that ensures that the testing kit is validated by various measures and gives the history of the supply chain of the testing kit. The parties that are used in the supply chain are Notary, Manufacturer, and Validating Party. A Consumer also plays an important role and can punch the batch number to check whether the kit is approved or not. The framework is developed using R3 Corda, a permissioned distributed ledger technology. A permissioned blockchain is used for data privacy and security so that only trusted parties can leave or join the system.

Mansi Gupta, Vimal Kumar, Vikash Yadav, Rajesh Kumar Singh & Mohd Sadim

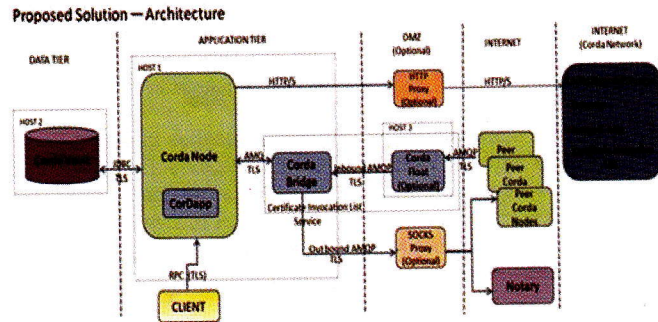

Science & Technology Management

276 Event Driven Application Specific Prioritized Data Transmission Approach for Underwater Wireless Sensor Networks

The paper presents a novel framework based on prioritized event detection for Underwater Wireless Sensor Network (UWSN). The proposed approach named Event Driven Energy Balanced Routing (EDEBR) takes the routing decision based on oceanic environment parameters (temperature, density, salinity and pressure). The approach of EDEBR considers two routing phase based on annotated parameters of Critical and Non-critical event priority. Here critical data routing phase focuses on fast and reliable delivery of data and Non-critical data routing phase focuses on the network lifetime through energy balancing technique. The proposal is evaluated and compared against the standard state-of-art protocol on the basis of following three evaluation parameters i) end to end delay, ii) Network lifetime and iii) Throughput of the network. Here in case of critical data the end to end delay is reduced this satisfies the condition for fast delivery.

Rakesh Kumar, Diwakar Bhardwaj & Manas Kumar Mishra

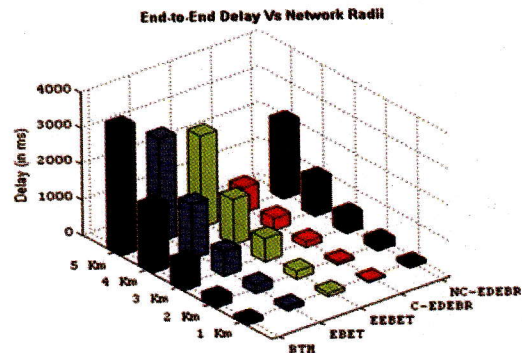

Author-Reader Platform

286 Instructions to Contributors

CONTENTS

Author Index

Babu B S S V R	255	Nayak S S	239
Bhardwaj D	276	Pal D	210
Blagojević M D	249	Papić M Ž	249
Chowdary P S R	255	Pugazhendi E	260
Duhan N	221	Ravuri V	239
Gad H M H	203	Sadim M	270
Gupta M	270	Satyasis M	255
Harika P L	260	Signh S K	210
Hassan M R	203	Singh B K	239
Hogade B G	230	Singh R K	210
Ibrahim S M	203	Singh R K	270
Karuović D I	249	Singh R S	210
Kulkarni P	230	Stanković N L	249
Kulkarni V	276	Sumalatha M R	260
Kumar R	270	Terlapu S K	239
Kumar V	276	Tripathi N	210
Mishra M K	239	Turkar V	230
Mukhopadhyay M		Yadav U	221
		Yadav V	270

Keyword Index

ALO	255	Fused Floating Point Addition-Subtraction	230
ANN	249	Health Care Industry	270
APSO	255	Knowledge acquisition	249
Big Data	221	Knowledge test	249
Building materials	210	Langmuir isotherm	203
Butterfly Unit	230	Large scale Ontology	221
Chemical Activation	203	MapReduce	221
Clay brick	210	Mixed-hop transmission	276
Cloud Computing	260	Multi-hop transmission	276
Cognitive radio	239	Non-redundant arithmetic	230
Compressed Sensing	245	Ontology Matching	221
Compressive strength	210	Pine Tree Sawdust	203
Corona virus	270	Programming skills	249
Decentralization	270	R3 Corda	270
Delay sensitive	276	Receiver Operating Characteristic	239
Depth based routing	276	Reconstruction	245
Detection probability	239	Sampling	245
Document Frequency	260	Side Lobe Level	255
Document Retrieval	260	SNR	239
Document Weight	260	Sorption	203
Dropbox Cloud	260	Sparse Signal Processing	245
EAA	255	Supply Chain Management	270
Efflorescence	210	Water absorption	210
Energy efficient	276	Web-based application	249
False alarm probability	239		
Fast Fourier Transform	230		
FPA	255		
Frequency Domain	245		
Freundlich isotherm	203		