

Course Code: EC409

Course Name: CONTROL SYSTEMS

Max. Marks: 100

Duration: 3 Hours

(Note: Provide normal and semilog graph sheet.)

PART A

Answer any two full questions, each carries 15 marks.

Marks

- 1 a) Determine the transfer function $X_1(s)/F(s)$ for the system shown below. (8)

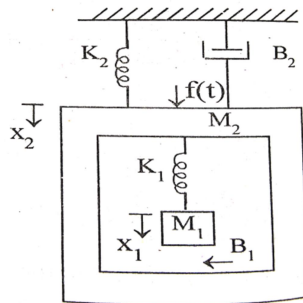

- b) Obtain the closed loop transfer function $C(s)/R(s)$ of the system by block reduction method (7)

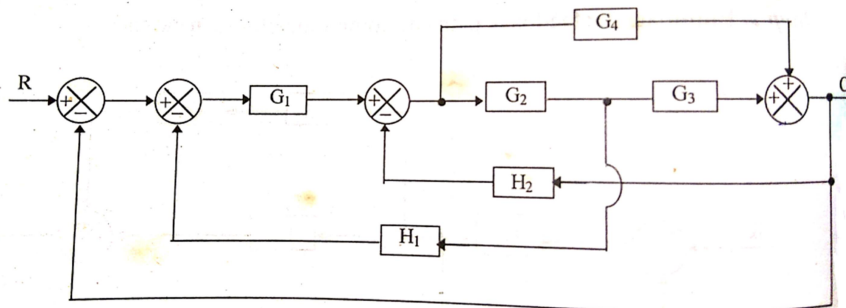

- 2 a) A positional control system with velocity feedback is shown. What is the response $c(t)$ to unit step input? Given that $\epsilon_s = 0.5$. Calculate rise time, peak time and settling time. (8)

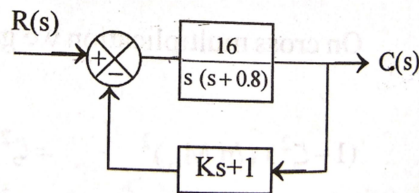

- b) The open loop transfer function of a unity feedback system is given as (3)

$$G(S) = \frac{10}{S(S+2)(S+5)}$$

Find the steady state error, if the input to the system is a unit ramp signal.

- c) Derive dynamic error coefficients. (4)
- 3 a) Derive an expression for time response of second order critically damped system to step input. (7)
- b) Construct the signal flow graph for the following set of linear algebraic equation and find the overall transfer function using Mason's gain formula. (8)

$$x_2 = x_1 - 3x_3 - 5x_4, \quad x_3 = 2x_2, \quad x_4 = 5x_3 + 3x_2, \quad x_5 = x_4.$$

PART B

Answer any two full questions, each carries 15 marks.

- 4 a) Sketch the root locus for the unity feedback system whose open loop transfer function is (9)

$$G(s)H(s) = \frac{K(s+5)}{s(s^2+4s+11)}.$$

- b) The open loop transfer function of a unity feedback system is given by (6)

$G(s) = \frac{K}{(s+2)(s+4)(s^2+6s+2)}$. By applying Routh criterion, discuss the stability of the closed loop system as a function of K. Determine the value of K which will cause sustained oscillations in the closed loop system. What are the corresponding oscillating frequencies?

- 5 a) Sketch the Bode diagram for the following transfer function and obtain gain and phase cross over frequencies. (10)

$$G(s) = \frac{K(s+20)}{(s+1)(s+2)(s+10)}$$

- b) Use Nyquist criterion to determine whether the closed loop system having the following open loop transfer function is stable or not. If not how many closed loop poles lie in the right half of s-plane (5)

$$G(S)H(S) = \frac{1}{s(s+2)(s+3)}$$

- 6 a) Write short notes on PID controllers. (6)
- b) Explain the effect of adding poles and zeros on the location of root locus with diagram. (9)

PART C

Answer any two full questions, each carries 20 marks.

- 7 a) Find the time response of the system given below. (7)

$$\dot{X} = AX$$

$$A = \begin{bmatrix} 0 & 1 \\ -2 & 0 \end{bmatrix}; \quad x(0) = \begin{bmatrix} 1 \\ 1 \end{bmatrix}; \quad y = [1 \quad -1] \begin{bmatrix} x_1 \\ x_2 \end{bmatrix}$$

b) A system is represented by the state model.

$$\begin{bmatrix} \dot{x}_1(t) \\ \dot{x}_2(t) \\ \dot{x}_3(t) \end{bmatrix} = \begin{bmatrix} 0 & 1 & 0 \\ 0 & 0 & 1 \\ -6 & -11 & -6 \end{bmatrix} \begin{bmatrix} x_1(t) \\ x_2(t) \\ x_3(t) \end{bmatrix} + \begin{bmatrix} 0 \\ 0 \\ 1 \end{bmatrix} U, \quad y = [0 \quad 2 \quad 0] \begin{bmatrix} x_1(t) \\ x_2(t) \\ x_3(t) \end{bmatrix} \quad (8)$$

Determine whether the system is completely controllable and observable.

c) Compute the state transition matrix when $A = \begin{bmatrix} -1 & 1 \\ 0 & 2 \end{bmatrix}$ (5)

8 a) Determine the stability of a sampled data control system using Jury's stability test having the following characteristic polynomial (10)

$$2z^4 + 8z^3 + 12z^2 + 5z + 1 = 0$$

b) Explain sampled data control system. (5)

c) Find the pulse transfer function for the error sampled system given. (5)

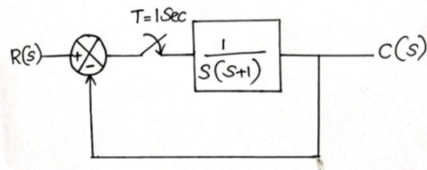

9 a) Obtain the state space representation of the transfer function (10)

$$\frac{C(s)}{R(s)} = \frac{K}{(s+1)(s+2)(s^2+1)}$$

b) Find the z-domain transfer function of a system with s-domain transfer function (5)

$$H(s) = \frac{3}{(s+3)^2}$$

c) Write short notes on Sample and hold circuit. (5)
