

Reg No.: \_\_\_\_\_

Name: \_\_\_\_\_

**APJ ABDUL KALAM TECHNOLOGICAL UNIVERSITY**

First Semester B.Tech Degree Regular and Supplementary Examination December 2022 (2019 Scheme)

**Course Code: EST 110****Course Name: ENGINEERING GRAPHICS  
(2019 -Scheme)**

Max. Marks: 100

Duration: 3 Hours

**Instructions: Retain Construction lines. Show necessary dimensions. Answer any ONE question from each module. Each question carries 20 marks.****MODULE 1**

- 1 A line PQ is 60 mm long has one of its ends on HP and 30 mm in front of VP. Draw the projections of the line if it is inclined at 30 degrees to HP and 45 degrees to VP. Locate the traces of the line and determine its apparent lengths and apparent inclinations.
- 2 The point M of a line MN is 15 mm above HP and 10 mm in front of VP and the other end N is 50 mm in front of the VP. The front view of the line has a length of 70 mm. The distance between the end projectors is 60 mm. Find the true length, plan length, true inclinations, and apparent inclinations of the line by drawing its projections. Also locate its traces.

**MODULE 2**

- 3 A rectangular prism of base 25 x 35 mm and height 50 mm is resting on VP on one of its longer base edges. Draw the projection of the solid when its axis inclined at 35 degrees to VP and the base edge resting on VP is inclined at 45 degrees to HP. Also assume that end face of the solid visible in front view is away from HP and located right side of the viewer.
- 4 Draw the projection of a pentagonal pyramid of 30 mm base side and 65 mm long axis is resting on one of its corners of the base on HP. The axis is inclined at 30 degrees to HP and top view of the axis is inclined at 35 degrees to XY line. Consider that apex is away from VP and is on the right side of the viewer.

**MODULE 3**

- 5 A hexagonal prism of base side 35 mm and height 65 mm rests on its base on HP with one of the base edges parallel to VP. It is cut by a section plane inclined towards right at an angle of 30 degrees to HP and perpendicular to VP. The section plane meets the axis

of the prism at a height of 45 mm from the base. Draw the front view, sectional top view, and true shape of the section.

- 6 Draw the development of the lateral surface a truncated right circular cone of base diameter 46 mm and height 64 mm, which is cut by a section plane inclined towards right at 30 degrees to HP and perpendicular to VP. Assume that the section plane is meeting the axis of the cone at 35 mm above the base. The cone is resting on HP on its base.

#### MODULE 4

- 7 Draw the isometric view of a triangular prism resting vertically on a circular disc with the axes of both the solids coinciding each other. The triangular prism is having a base edge of 30 mm and height 50 mm. The circular disc is of 60 mm diameter and 40 mm thick. Assume that one of the base edges of the triangular prism is parallel to VP, which is nearer to it and the combination of the solids is lying on the ground on one of the end faces of the circular disc.

- 8 A sphere of diameter 60 mm is resting centrally on top of a pentagonal prism which is on HP on one of its end faces. Prism is having a base edge of 30 mm and altitude 40 mm. If the axes of both the solids are coinciding with each other, draw the isometric view of the combination of solids. One of the base edges of the prism is perpendicular to VP and it is on the left side of the viewer.

#### MODULE 5

- 9 A rectangular prism of 40 mm x 20 mm x 15 mm size is lying on its 40 mm x 20 mm rectangular face on the ground plane with a vertical edge parallel and 10 mm behind picture plane and end faces inclined at 30 degrees with the picture plane. The central plane is 60 mm away from the axis of the prism towards left. The station point is situated 50 mm in front of the picture plane and 45 mm above the ground plane. Draw the perspective view of the prism.

- 10 Draw the front view, top view, and left side view of the object given below. Front view should be drawn as seen in the direction of the arrow X. Assume dimensions suitably if found missing.

0100EST110022301

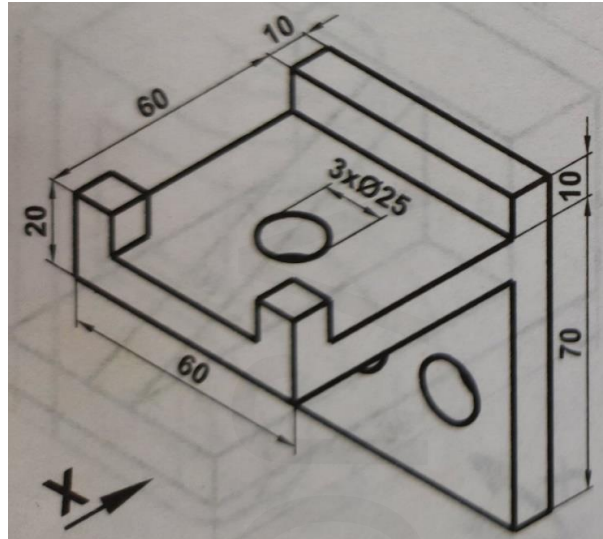

(5 x 20 = 100 Marks)

\*\*\*