

Reg No.: _____

Name: _____

APJ ABDUL KALAM TECHNOLOGICAL UNIVERSITY
Second Semester B.Tech Degree Examination June 2022 (2019 scheme)

Course Code: EST110

Course Name: ENGINEERING GRAPHICS

(2019 -Scheme)

Max. Marks: 100

Duration: 3 Hours

Instructions: Retain Construction lines. Show necessary dimensions. Answer any ONE question from each module. Each question carries 20 marks.

MODULE 1

- 1 One end point of a line AB is 12 mm above HP and is 15 mm in-front of VP. Other end point is 50 mm above HP and is 42 mm in front of VP. Draw the projections of the line AB if its elevation measures 70 mm. Find out its true length and the true inclinations with respect to the reference planes.
- 2 One end point P of a line PQ, 75 mm long, is 10 mm above HP and 20 mm in front of VP. The line is inclined 45° to HP and its plan is inclined 35° to x-y line. Draw the projections of the line PQ and find out true inclination of the line with respect to VP.

MODULE 2

- 3 A hexagonal prism base 20 mm side and axis 40 mm long is placed with one of its base edges on the HP such that the axis is inclined at 30° to HP and 45° to VP. Draw the projections of the prism.
- 4 A cone of base diameter 50 mm and axis length 60 mm is resting on VP on one of its generators with the front view of the axis inclined at 40° to HP. Draw its projections.

MODULE 3

- 5 A hexagonal pyramid, side of base 25 mm and altitude 70 mm long, rests with its base on HP with two of its base sides parallel to VP. It is cut by a section plane perpendicular to VP, inclined at 45° to HP and passing through the axis 15mm from the base. Draw the sectional top view and true shape of the section.
- 6 A pentagonal pyramid, side of base 50 mm and height 80 mm rests on its base on the ground with one of its base sides parallel to VP. A section plane perpendicular to VP

and inclined at 30° to HP cuts the pyramid, bisecting its axis. Draw the development of the truncated pyramid.

MODULE 4

- 7 A square pyramid of base edge 20 mm and height 40 mm is mounted centrally on a face of a cube of base edge 50 mm. Draw the isometric projection of the objects.
- 8 Draw the isometric projections of a hexagonal prism with edge of base 30 mm and axis 60 mm when it rests on a rectangular face on the ground.

MODULE 5

- 9 A square pyramid of base side 30 mm and height 45 mm is resting on the ground plane. The nearest edge of the base is parallel to and 20 mm behind the Picture Plane (PP). The station point is situated at a distance of 70 mm in front of the PP, 40 mm to the right of the axis of the pyramid, and 60 mm above the ground. Draw the perspective view of the pyramid.
- 10 Draw the front view, top view, and side view of the object given below. Front view should be drawn as seen in the direction of the arrow X.

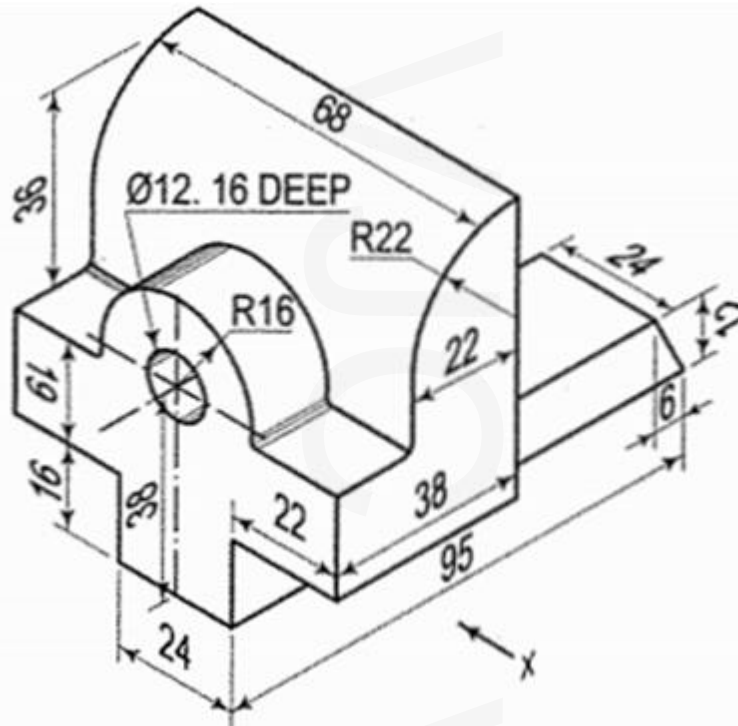

(5 x 20 = 100 Marks)
