

Reg No.: _____

Name: _____

APJ ABDUL KALAM TECHNOLOGICAL UNIVERSITY
Second Semester B.Tech Degree (R,S) Examination May 2024 (2019 Scheme)

Course Code: EST 110
Course Name: ENGINEERING GRAPHICS
(2019 -Scheme)

Max. Marks: 100

Duration: 3 Hours

Instructions: Retain Construction lines. Show necessary dimensions. Answer any ONE question from each module. Each question carries 20 marks.

MODULE 1

- 1 The end A of a line AB (True length 100mm) is 10 mm above HP and 20 mm in front of VP. The line AB is inclined at 30 degrees to the HP and 20 degrees to VP. Draw the projections of the line if the end B is in third quadrant and mark its traces.
- 2 One end of line AB is 10 mm above HP and other end is 70 mm in front of VP. It's FV is 20 degrees inclined to xy while it's HT & VT are 10 mm and 5 mm below xy respectively. Draw projections and find TL with its inclinations with HP & VP.

MODULE 2

- 3 A square prism of base 30 mm and length 60 mm has a base edge on VP, axis inclined at 30 degrees to VP and resting base edge is inclined at 40 degree to HP. Draw the projection of the solid.
- 4 Draw projections of a cone of base diameter 50 mm and height 50 mm resting on HP on its generator with top view of axis inclined 30 degree to VP.

MODULE 3

- 5 A hexagonal pyramid of base 30 mm and axis 60 mm rests on its base on HP with two base edges perpendicular to VP. It is cut by a plane perpendicular to VP and inclined at 30 degree to the HP meeting the axis at 25 mm from the vertex. Draw the elevation, sectional plan and true shape of the section. What is the maximum true length of the side in the section of the pyramid
- 6 Draw the development of the lateral surface of a right regular hexagonal prism of 20 mm base edge and 60 mm height. An ant moves on its surface from a corner on the base

to the diametrically opposite corner of the top face by the shortest route. Sketch the path of the ant in the elevation.

MODULE 4

- 7 A frustum of a cone of base diameter 50 mm, top diameter 30 mm and height 50 mm resting upon its base on HP. Draw the isometric view of the frustum
- 8 Draw the isometric projection of a sphere of 50 mm diameter resting centrally on a cube of side 30 mm.

MODULE 5

- 9 A cube of 30 mm side is placed vertically with one of its edges on the picture plane and the top square end face touching an auxiliary ground plane at a height of 50 mm above the horizontal plane. The vertical edge formed by the two adjacent rectangular faces which are inclined at 45 degrees to the picture planes touches the picture plane. Draw the perspective view of the cube if the station point is 70 mm in front of the picture plane and lies in the central plane which is 30 mm to the left side of the centre of the cube.
- 10 Draw the orthographic projections (front view, top view and left side view) of the following figure. The front view direction is marked with a long arrow. Any missing dimension may be suitably assumed. All dimensions are in mm

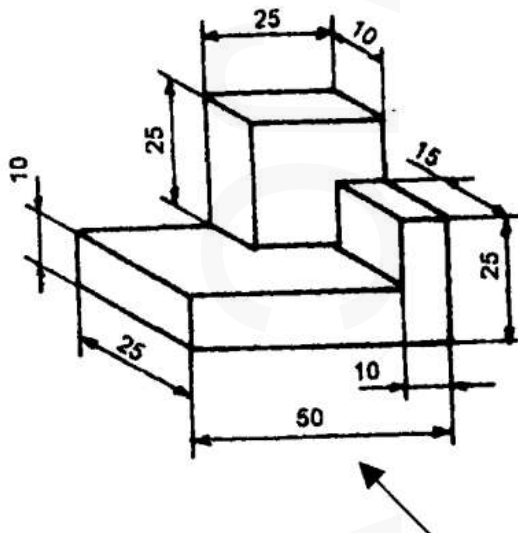

(5 x 20 = 100 Marks)
